

SLR Line Reactors

SolaHD introduces DIN Rail mounted line reactors as the latest addition to a family of power quality products with a reputation for increasing industrial automation system performance.

The SLR Series is a CE style, DIN Rail Mounted line reactor that provides safe, compact protection for high frequency drives and electronic equipment. The SLR inductive filter prevents damage to any three phase electronic system plagued by capacitor or large load switching. Other benefits include reduced harmonics and input line distortion.

For SCR drive protection, SolaHD recommends our Drive Isolation Transformers (from 7.5 to 440 kVA) to completely isolate the negative effects of SCR drive technology.

No matter what the drive protection, SolaHD has the complete solution.

Applications

- Variable Frequency Drives
- Any three phase electronic products subject to high current anomalies such as Power Factor Correction capacitor switching.
- SCR Drives

Related Products

- Drive Isolation Transformers
- K-13 Rated Transformers for Variable Speed Drives



Features

- Compact, IP 20 finger safe packaging
- 2-20 HP available
- DIN Rail mount through 20 HP
- Reduces stress on drive components keeping drives running longer
- Removes harmonics and helps keep line voltage smooth through notching
- Reduces nuisance tripping to provide stable system performance
- Eliminates drive cross-talk and interference
- 10-Year warranty

Selection Table

Catalog Number	Power	Output Amperage	Impedance (%Z)	mH	Phase	I/O Voltage	Mounting	Dimensions (H x W x D) – in (mm)	Ship Weight lbs (kg)
SLR-2H-480-3	2 HP	3.4 A	3	5513	3	480 VAC	DIN Rail	4.84 x 4.80 x 4.56 (123 x 122 x 116)	6 (2.72)
SLR-3H-480-3	3 HP	4.8 A		3675					6 (2.72)
SLR-5H-480-3	5 HP	7.6 A		2757					6 (2.72)
SLR-7H-480-3	7.5 HP	11.0 A		1838					7 (3.17)
SLR-10H-480-3	10 HP	14.0 A		1376				7 (3.17)	
SLR-15H-480-3	15 HP	21.0 A		1050				9 (4.08)	
SLR-20H-480-3	20 HP	27.0 A		817				16 (7.26)	

MODEL 153

Reverse Phase Relay

- Senses phase reversal on Wye or Delta
- 190 to 500 VAC range
- Surface-mount Enclosure
- Low power consumption

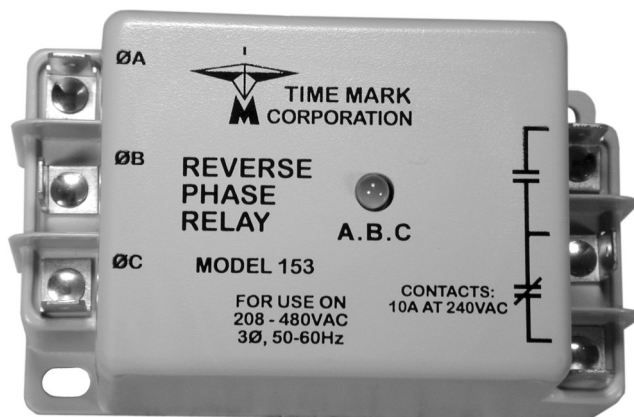

DESCRIPTION

The **Model 153 Reverse Phase Relay** is designed to continuously monitor phase rotation of 3-phase lines. This device should be used in applications where proper phase rotation is critical, such as fan motors, compressors, grinders, elevators, etc.

The solid-state sensing circuit drives an internal electromechanical relay which energizes when power, *with correct phase rotation*, is applied.

The relay will not energize if the applied phases are reversed. It will de-energize if phase rotation is reversed while the motor is running. An LED indicator will illuminate with correct A B C phase rotation.

DIMENSIONS

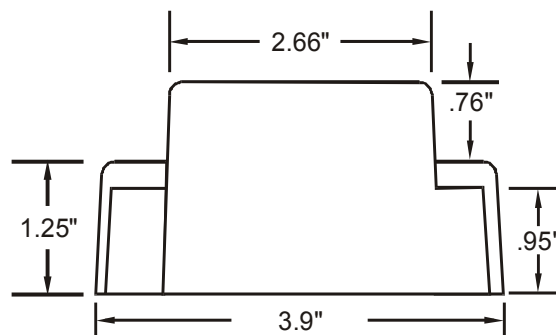
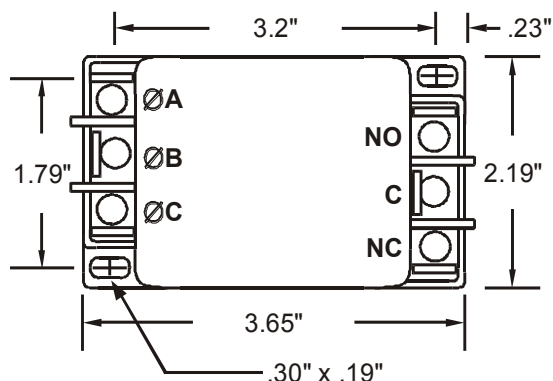

SPECIFICATIONS

Model	153
Nominal voltage	190-500 VAC (phase to phase)
Frequency	50 to 60 Hz
Power Consumption	2W per phase
Transient protection	2500 VRMS for 10 msec
Repeat accuracy	± 0.1 % (fixed conditions)
Response time	.05 seconds
Reset time	.05 seconds
Reset type	Automatic
Dead band	Approximately 2 %
Output contacts	SPDT 10A at 240 VAC resistive
Expected relay life	Mechanical: 10 million operations Electrical: 100,000 at rated load
Operating temp	- 20° to +131° F
Humidity tolerance	0-97 % w/o condensation
Case material	ABS plastic
Mounting	Surface
Weight	4 oz.

Telephone: Main - (918) 438-1220

Sales - (800) 862-2875

Fax: (918) 437-7584

E-mail: sales@time-mark.com

Internet: <http://www.time-mark.com>



TIME MARK
CORPORATION

11440 East Pine Street
Tulsa, Oklahoma 74116

07/2011

© 2011 TIME MARK CORPORATION

TIME MARK is a division of  AEMT, Inc.

MODEL 153 Reverse Phase Relay

READ ALL INSTRUCTIONS BEFORE INSTALLING, OPERATING OR SERVICING THIS DEVICE.
KEEP THIS DATA SHEET FOR FUTURE REFERENCE.

GENERAL SAFETY

POTENTIALLY HAZARDOUS VOLTAGES ARE PRESENT AT THE TERMINALS OF THE MODEL 153.
ALL ELECTRICAL POWER SHOULD BE REMOVED WHEN CONNECTING OR DISCONNECTING WIRING.
THIS DEVICE SHOULD BE INSTALLED AND SERVICED BY QUALIFIED PERSONNEL.

Installation Instructions

INSTALLATION

Mount the Model 153 in the desired location.

Connect the 3-phase power to the terminals marked **A**, **B**, and **C**.

Connect the control circuit to the terminals with the contact markings. Refer to the Typical Application wiring diagram for additional information.

If the relay contacts do not transfer when power is applied (LED indicator-Off), check that all three voltages are correct.

If power is present and the voltage is correct, remove power. Reverse two of the three phase connections. Re-apply power.

The contacts should transfer to the normal condition (normally open contacts closed; LED indicator-On). Calibrations or adjustments are not required.

TROUBLESHOOTING

Should the relay fail to operate properly, check that all three voltages are present and are of the correct level. Check all fuses and verify that all wiring connections are correct. Should problems persist, contact the factory for assistance.

TYPICAL APPLICATION

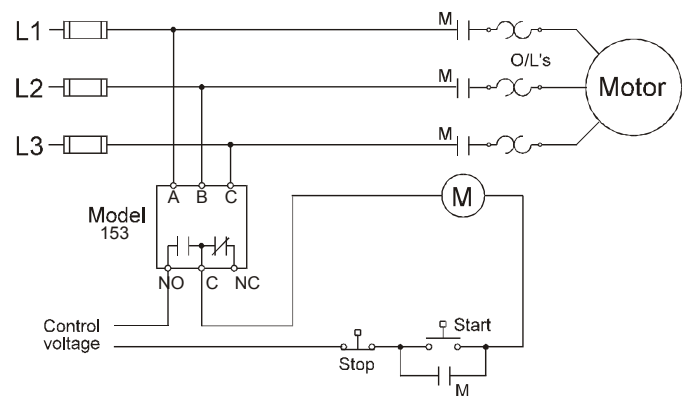

WARRANTY

The **Model 153 Reverse Phase Relay** is covered by Time Mark Corporation's exclusive **5-Year Unconditional Warranty**. Should this device fail, for any reason, within five years from the date of purchase, we will repair or replace it. Contact the Time Mark Sales department, Monday through Friday; 8 a.m. to 5 p.m., CST, for further details.

Telephone: Main - (918) 438-1220
Sales - (800) 862-2875
Fax: (918) 437-7584

E-mail: sales@time-mark.com
Internet: http://www.time-mark.com



TIME MARK
CORPORATION

11440 East Pine Street
Tulsa, Oklahoma 74116

07/2011

© 2011 TIME MARK CORPORATION

TIME MARK is a division of  AEMT, Inc.

MODEL 158 MODEL 158R

3-Phase Monitor

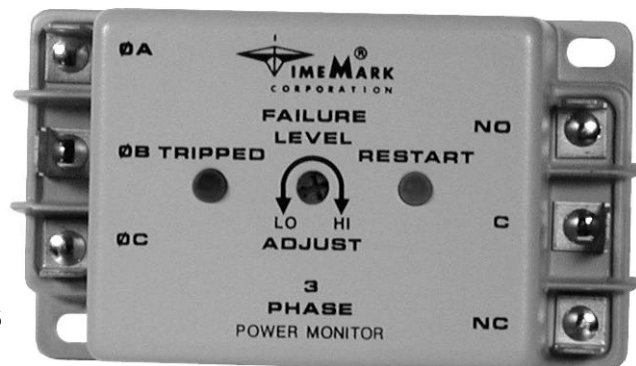

- Surface-mount for HVAC Applications
- Optional 5 Minute Short Cycle Time Delay
- Detect Phase Loss, Low Voltage, Phase Reversal
- 5 Year Unconditional Warranty

DESCRIPTION

The **Model 158** continuously monitors 3-phase power lines for abnormal conditions. When properly adjusted, the Model 158 monitor will detect phase loss on a loaded motor even when regenerated voltage is present.

This device consists of a solid-state voltage and phase-angle sensing circuit, driving an electro-mechanical relay. When correct voltage and phase rotation are applied, the internal relay will energize. A fault condition will de-energize the relay. When the fault is corrected, the monitor will automatically reset.

The Model 158 does not require a neutral connection, and can be used with Wye or Delta systems. Four versions cover 120V, 208/240V, 480V (60 Hz) and 380V (50 Hz). Voltage ranges are sufficient to allow for proper adjustment to existing conditions. A front-mounted LED failure indicator is provided.

The "R" versions of the Model 158 Monitor have an additional LED indicator for RESTART, and a 5 minute short cycle timer, to delay restarting the motor.

SPECIFICATIONS

MODEL	B158B	158B	A158B	EX158B
Input Voltage	120vac	208/240vac	480vac	380vac
Adjustment Range	85-125vac	160-260vac	380-500vac	300-400vac
Frequency	60 Hz	60 Hz	60 Hz	50 Hz
Power Consumption (per phase)	.25 W	.5 W	1.5 W	1.25 W
Transient Protection	2500 VRMS of 10 msecs			
Repeat Accuracy	± 0.1% of setpoint (fixed conditions)			
Response Time	0.5 seconds			
Reset Time	Short cycle restart delay - 2 seconds "R" versions - 5 minutes			
Reset Type	Automatic			
Dead Band	2%			
Output contacts	SPDT	10A at 240vac	resistive	
Expected Relay Life	Mech: 10 million operations Elec: 100,000 operations at rated load			
Operating Temp	-20° to +131° F			
Humidity Tolerance	97% w/o condensation			
Enclosure Material	ABS plastic			
Mounting	Surface			
Weight	5 oz.			

ADDITIONAL ORDERING INFO:

add an "R" to any 158 model number above, for the 5 minute time delay option

DIMENSIONS

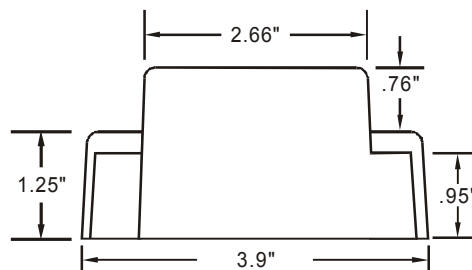
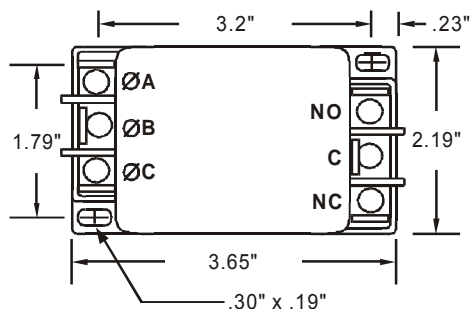

Telephone: Main - (918) 438-1220
Sales - (800) 862-2875
Fax: (918) 437-7584

E-mail: sales@time-mark.com
Internet: http://www.time-mark.com



11440 East Pine Street
Tulsa, Oklahoma 74116

Doc No. 87A254 07/2011
© 2011 TIME MARK CORPORATION

TIME MARK is a division of  AEMT, Inc.

MODEL 158 (R) 3-Phase Monitor

READ ALL INSTRUCTIONS BEFORE INSTALLING, OPERATING OR SERVICING THIS DEVICE.
KEEP THIS DATA SHEET FOR FUTURE REFERENCE.

GENERAL SAFETY

POTENTIALLY HAZARDOUS VOLTAGES ARE PRESENT AT THE TERMINALS OF THE MODEL 158.
ALL ELECTRICAL POWER SHOULD BE REMOVED WHEN CONNECTING OR DISCONNECTING WIRING.
THIS DEVICE SHOULD BE INSTALLED AND SERVICED BY QUALIFIED PERSONNEL.

Installation Instructions

INSTALLATION

Mount the Model 158 3-Phase Monitor in a suitable enclosure.

Attach 1/4" terminal lugs to the input voltage wires, and then connect them to the terminals on the Model 158 marked $\emptyset A$, $\emptyset B$, and $\emptyset C$. Proper **clockwise** phase rotation should be confirmed, using a Time Mark Model 108A or 108B Phase Rotation Indicator or unit will show trip for Phase Reversal.

Attach 1/4" terminal lugs to the load control circuit wires, then connect them to the terminals marked **C** and **NO**.

Apply power. The **NO** contact will close when correct voltage is applied. **If a Model 158R is being installed, there will be a 5 minute delay before the contact transfers. The green RESTART light should be ON during this 5 minute period.**

ADJUSTMENT PROCEDURE

NOTE: While adjusting the trip level, you may wish to jumper the control circuit contacts to prevent the device from tripping the load on and off.

Slowly rotate the FAILURE LEVEL ADJUST pot clockwise, until the TRIPPED indicator LED just illuminates, and the contacts transfer.

Rotate the FAILURE LEVEL ADJUST pot counter-clockwise, until the TRIPPED indicator LED goes out, and the contacts re-energize. **On the "158R" version, the green RESTART light will be ON, and there will be a 5 minute delay period before the contacts re-energize.**

Should nuisance tripping occur, after completing these adjustments, turn the FAILURE LEVEL ADJUST pot slightly further counter-clockwise, as necessary. **Remove the jumper from the control circuit contact, if one was applied.**

TROUBLESHOOTING

There are no user-serviceable parts in the Model 158 3-Phase Monitor. Should the unit fail to operate properly, check that correct voltage and clockwise phase rotation are being applied. Check all fuses and wiring connections. Should problems persist, contact your local Time Mark Distributor, or the factory at 800-862-2875 (Monday-Friday; 8 a.m. to 5 p.m. CST), for further assistance.

APPLICATION DIAGRAMS

Typical compressor application

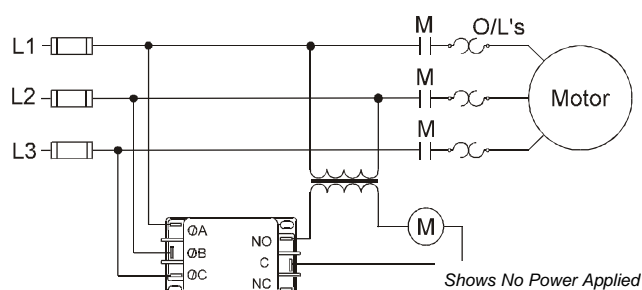

Typical motor control application

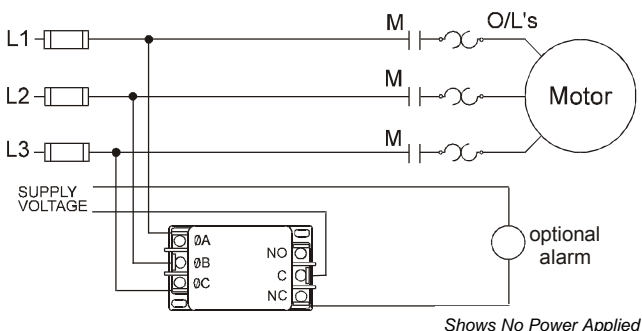

WARRANTY

The **Model 158 3-Phase Monitor** is warranted to be free from defects in materials and workmanship, and is covered by our exclusive **5-year Unconditional Warranty**. If the Model 158 fails to operate, for any reason, we will repair or replace it free, for five years from the date of purchase. Contact the Time Mark Sales department, Monday through Friday; 8 a.m. to 5 p.m., CST, for further details.

Telephone: Main - (918) 438-1220
Sales - (800) 862-2875
Fax: (918) 437-7584

E-mail: sales@time-mark.com
Internet: http://www.time-mark.com



TIME MARK
CORPORATION

11440 East Pine Street
Tulsa, Oklahoma 74116

Doc No. 87A254 07/2011
© 2011 TIME MARK CORPORATION

TIME MARK is a division of  **AEMT, Inc.**

MODEL 200

3-Phase Voltage Unbalance Monitor

- Detects Unbalanced Voltages
- Percent of Unbalance Adjustment
- Automatic Reset



DESCRIPTION

The Model 200 3-Phase Voltage Unbalance Monitor is designed to continuously monitor a three-phase line for unbalanced voltage conditions.

This device will only energize the relay if an unbalance exists. Zero volts on all three phases is considered a balanced condition. This allows the Model 200 to be used with shunt breakers, so that main power can be restored without resetting breakers.

The solid-state sensing circuit drives an internal electromechanical relay. Indicator lights on the monitor show when the voltage balance is within an acceptable range; when an unbalance exists; and when the relay is actually tripped.

When an acceptable voltage balance is reapplied, the Model 200 will automatically reset the relay.

DIMENSIONS

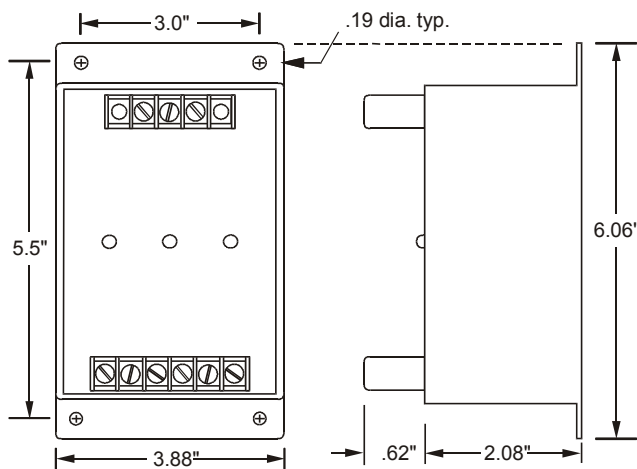

SPECIFICATIONS

Model	A200	B200A	B200B	C200	D200	EX200
Nominal AC Voltages	120VAC	208VAC	240VAC	480VAC	575VAC	380VAC
Voltage Range	± 15%	± 15%	± 15%	± 15%	+5 to -15%	± 15%
Frequency	60Hz	60Hz	60Hz	60Hz	60Hz	50Hz
Power Consumption (per phase)	0.5W	1W	1W	2W	2W	2W
Transient Protection	2500VRMS for 10msec					
Repeat Accuracy	± 0.1% (fixed conditions)					
Unbalance Adjustment	2% to 10%					
Response Time	100 msec					
Reset Time	Fixed 1 sec					
Dropout Time	Adjustable 0.2 to 20 seconds					
Reset Type	Automatic					
Dead Band	0.5% max					
Contact Rating	DPDT 10 amps at 240VAC resistive					
Expected Relay Life	Mech: 10 million operations Elec: 100,000 operations at rated load					
Operating Temp	- 20° to +131° F					
Humidity Tolerance	0-97% w/o condensation					
Mounting	Surface					
Enclosure Material	ABS plastic					
Weight	10 oz.					

Telephone: Main - (918) 438-1220
Sales - (800) 862-2875
Fax: (918) 437-7584

E-mail: sales@time-mark.com
Internet: http://www.time-mark.com



11440 East Pine Street
Tulsa, Oklahoma 74116

Doc No. 87A320 07/2011
© 2011 TIME MARK CORPORATION

TIME MARK is a division of  AEMT, Inc.

MODEL 200

3-Phase Voltage Unbalance Monitor

READ ALL INSTRUCTIONS BEFORE INSTALLING, OPERATING OR SERVICING THIS DEVICE.
KEEP THIS DATA SHEET FOR FUTURE REFERENCE.

GENERAL SAFETY

POTENTIALLY HAZARDOUS VOLTAGES ARE PRESENT AT THE TERMINALS OF THE MODEL 200.
ALL ELECTRICAL POWER SHOULD BE REMOVED WHEN CONNECTING OR DISCONNECTING WIRING.
THIS DEVICE SHOULD BE INSTALLED AND SERVICED BY QUALIFIED PERSONNEL.

Installation Instructions

INSTALLATION

Set PERCENT OF UNBALANCE fully clockwise.

Set TRIP DELAY IN SECONDS fully counter-clockwise.

Connect the 3-phase wires to the terminals marked 'A', 'B' and 'C'.

Connect the control wires to the terminals with the relay contact markings. The contact markings on the unit are the NORMAL or OFF condition of the contacts.

Apply power. NORMAL indicator should be ON.

ADJUSTMENT

Rotate the PERCENT OF UNBALANCE adjustment pot to the desired setting.

Set the TRIP DELAY adjustment to the desired amount of delay to prevent nuisance trips.

Should nuisance trips occur, increase the TRIP DELAY IN SECONDS setting. Any adjustments should be made in very small increments.

WARRANTY

The **Model 200 3-Phase Voltage Unbalance Monitor** is covered by Time Mark Corporation's exclusive **5-Year Unconditional Warranty**. Should this device fail, for any reason, within five years from the date of purchase, we will repair or replace it free. Contact the Time Mark Sales department, Monday through Friday; 8 a.m. to 5 p.m., CST, for further details.

TYPICAL MOTOR APPLICATION

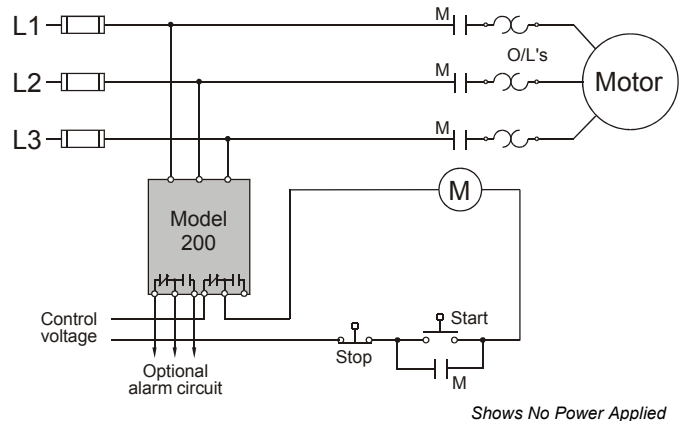

TYPICAL SHUNT BREAKER APPLICATION

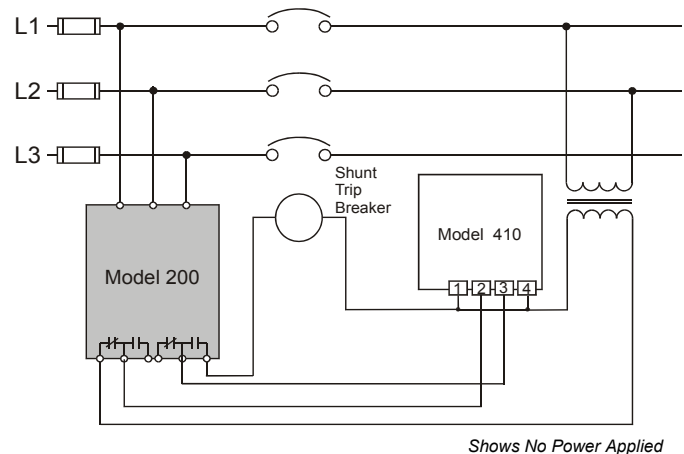

Telephone: Main - (918) 438-1220
Sales - (800) 862-2875
Fax: (918) 437-7584

E-mail: sales@time-mark.com
Internet: http://www.time-mark.com



11440 East Pine Street
Tulsa, Oklahoma 74116
Doc No. 87A320 07/2011
© 2011 TIME MARK CORPORATION

TIME MARK is a division of  AEMT, Inc.

MODEL 2002Y

3-Phase Voltage Unbalance Monitor

- Detects Unbalanced Voltages On Wye Connections
- Percent of Unbalance Adjustment
- Automatic Reset
- Can Energize Relay w/ only 1 Phase and Neutral Connection

DESCRIPTION

The Model 2002Y 3-Phase Voltage Unbalance Monitor is designed to continuously monitor a three-phase line with a neutral connection for unbalanced voltage conditions.

This device will only energize the relay if an unbalance exists. Zero volts on all three phases is considered a balanced condition. This allows the Model 2002Y to be used with shunt breakers, so that main power can be restored without resetting breakers.

The solid-state sensing circuit drives an internal electromechanical relay. Indicator lights on the monitor show when the voltage balance is within an acceptable range; when an unbalance exists; and when the relay is actually tripped.

DIMENSIONS

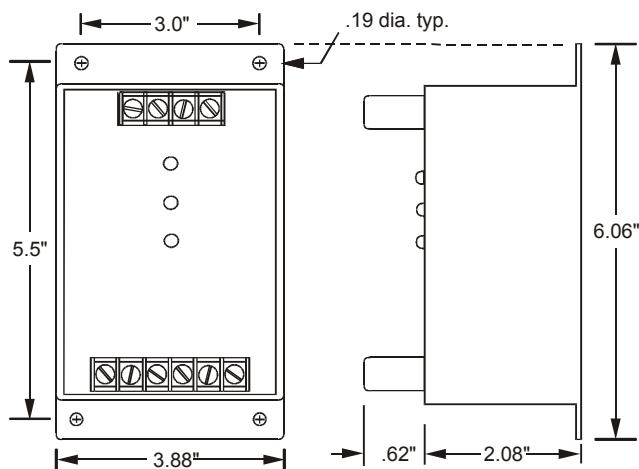

SPECIFICATIONS

Model 2002Y-XXX/YYY	2002Y- 69/120	2002Y- 120/208	2002Y- 138/240	2002Y- 220/380	2002Y- 240/415	2002Y- 277/480
Phase-Neutral Voltage	69 VAC	120 VAC	138 VAC	220 VAC	240 VAC	277 VAC
Phase-Phase Voltage	120 VAC	208VAC	240VAC	380VAC	415VAC	480VAC
Voltage Range	± 15%	± 15%	± 15%	± 15%	± 15%	± 15%
Frequency	50Hz - 60Hz					
Power Consumption (per phase max)	2.0W	2.0W	2.0W	2.0W	2.0W	2.0W
Transient Protection	2500VRMS for 10msec					
Repeat Accuracy	± 0.1% (fixed conditions)					
Unbalance Adjustment	2% to 10%					
Response Time	150 msec					
Reset Time	Fixed 1 sec					
Dropout Time	Adjustable 0.2 to 20 seconds					
Reset Type	Automatic					
Dead Band	0.5% max					
Contact Rating	DPDT 10 amps at 240VAC resistive					
Expected Relay Life	Mech: 10 million operations Elec: 100,000 operations at rated load					
Operating Temp	- 20° to +131° F					
Humidity Tolerance	0-97% w/o condensation					
Mounting	Surface					
Enclosure Material	ABS plastic					
Weight	10 oz.					

Telephone: Main - (918) 438-1220
Sales - (800) 862-2875
Fax: (918) 437-7584

E-mail: sales@time-mark.com
Internet: http://www.time-mark.com



11440 East Pine Street
Tulsa, Oklahoma 74116

Doc No. 87A320 07/2011
© 2011 TIME MARK CORPORATION

TIME MARK is a division of  AEMT, Inc.

MODEL 2002Y 3-Phase Voltage Unbalance Monitor

READ ALL INSTRUCTIONS BEFORE INSTALLING, OPERATING OR SERVICING THIS DEVICE.
KEEP THIS DATA SHEET FOR FUTURE REFERENCE.

GENERAL SAFETY

POTENTIALLY HAZARDOUS VOLTAGES ARE PRESENT AT THE TERMINALS OF THE MODEL 2002Y.
ALL ELECTRICAL POWER SHOULD BE REMOVED WHEN CONNECTING OR DISCONNECTING WIRING.
THIS DEVICE SHOULD BE INSTALLED AND SERVICED BY QUALIFIED PERSONNEL.

Installation Instructions

INSTALLATION

Set PERCENT OF UNBALANCE fully clockwise.

Set TRIP DELAY IN SECONDS fully counter-clockwise.

Connect the 3-phase wires to the terminals marked 'A', 'B' and 'C' and neutral connection to 'N'.

Connect the control wires to the terminals with the relay contact markings. The contact markings on the unit are the NORMAL or OFF condition of the contacts.

Apply power. NORMAL indicator should be ON.

ADJUSTMENT

Rotate the PERCENT OF UNBALANCE adjustment pot to the desired setting. The percentage of unbalance is calculated as follows using phase to neutral voltages:

$$\% \text{ Unbalance} = \frac{V_{\max} - V_{\min}}{V_{\max}} \times 100$$

Set the TRIP DELAY adjustment to the desired amount of delay to prevent nuisance trips.

Should nuisance trips occur, increase the TRIP DELAY IN SECONDS setting. Any adjustments should be made in very small increments.

WARRANTY

The **Model 2002Y 3-Phase Voltage Unbalance Monitor** is covered by Time Mark Corporation's exclusive **5-Year Unconditional Warranty**. Should this device fail, for any reason, within five years from the date of purchase, we will repair or replace it free. Contact the Time Mark Sales department, Monday through Friday; 8 a.m. to 5 p.m., CST, for further details.

TYPICAL MOTOR APPLICATION

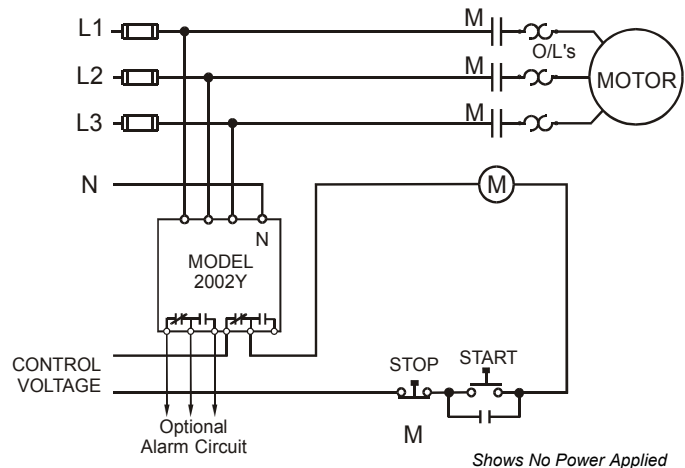

TYPICAL SHUNT BREAKER APPLICATION

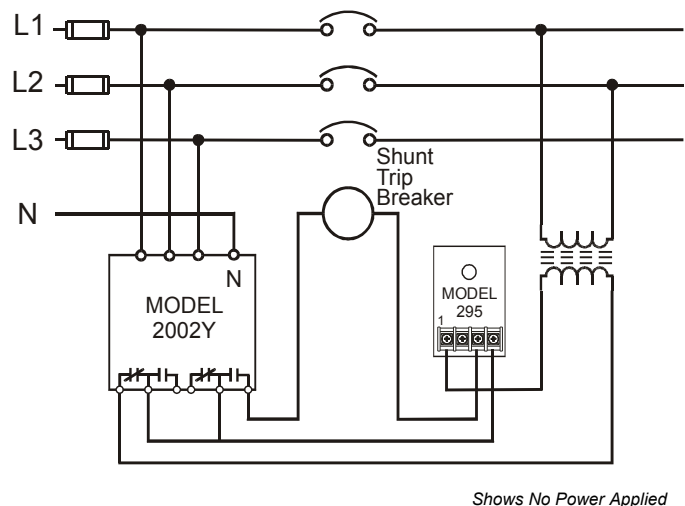

Telephone: Main - (918) 438-1220
Sales - (800) 862-2875
Fax: (918) 437-7584

E-mail: sales@time-mark.com
Internet: http://www.time-mark.com



TIME MARK
CORPORATION

11440 East Pine Street
Tulsa, Oklahoma 74116
Doc No. 87A320 07/2011
© 2011 TIME MARK CORPORATION

TIME MARK is a division of  AEMT, Inc.

MODEL 246

3-Phase Monitor



- Monitors for Phase Loss or Reversal, Low and Over Voltage
- Automatic Reset
- CSA Certified
- 5 Year Unconditional Warranty



DESCRIPTION

The **Model 246 3-Phase Monitor** is designed to continuously monitor 3-phase power lines for phase loss, phase reversal, low voltage and high voltage. This device features solid-state voltage and phase angle sensing circuits, which drive a SPDT electromechanical relay. A neutral is not required, allowing the Model 246 to be used with either Wye or Delta systems.

Three versions of the Model 246 cover the 120 and 208/240VAC, 60 Hz and the 380VAC, 50 Hz. In addition, the models **A246** and **B246** are now **CSA Certified**.

Each option on the Model 246 monitor is adjustable throughout its operating range. The adjustment pots and LED indicators for OVER VOLTAGE and UNDER VOLTAGE are mounted on the front of the unit for easy access.

SPECIFICATIONS

Model	A246	B246	EX246
Nominal AC Voltage	120	208/240	380
Adjustment Range			
Low:	85-125 V	160-260 V	300-400 V
High:	110-140 V	210-280 V	350-450 V
Frequency	60 Hz	60 Hz	50 Hz
Power Consumption (per phase)	1 W	1.5 W	2 W
Transient Protection	2500V for 10 msec		
Repeat Accuracy	±0.1% of set point (fixed conditions)		
Response/Reset Time	50 msec		
Reset type	Automatic		
Dead Band	2%		
Contact Rating	SPDT 10A at 240VAC resistive		
Expected Relay Life	Mech: 10 million operations Elec: 100,000 at rated load		
Operating Temperature	- 20° to +131° F		
Humidity Tolerance	0-97% w/o condensation		
Enclosure Material	ABS plastic		
Weight	6 oz.		
Mounting	8-pin socket *order separately		
Agency approval	CSA	CSA	

* Order 8-pin socket number 51X120

TYPICAL APPLICATION

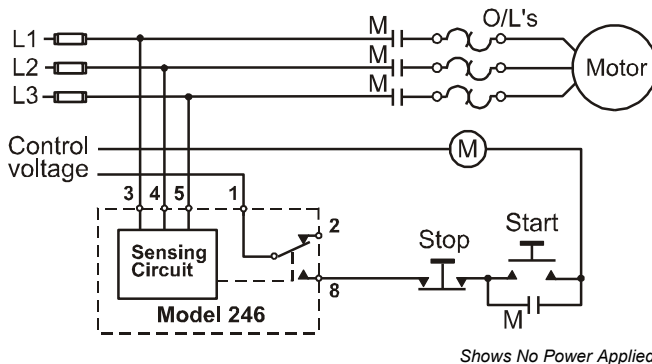

DIMENSIONS

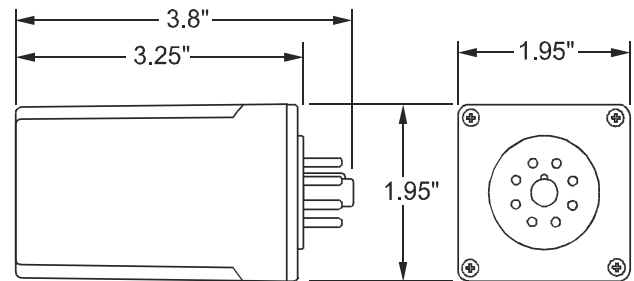

Telephone: Main - (918) 438-1220
Sales - (800) 862-2875
Fax: (918) 437-7584
E-mail: sales@time-mark.com
Internet: http://www.time-mark.com



TIME MARK
CORPORATION

11440 East Pine Street
Tulsa, Oklahoma 74116

Doc No. 87A112 07/11
© 2011 TIME MARK CORPORATION

TIME MARK is a division of AEMT, Inc.

MODEL 246 3-Phase Monitor

READ ALL INSTRUCTIONS BEFORE INSTALLING, OPERATING OR SERVICING THIS DEVICE.
KEEP THIS DATA SHEET FOR FUTURE REFERENCE.

GENERAL SAFETY

POTENTIALLY HAZARDOUS VOLTAGES ARE PRESENT AT THE TERMINALS OF THE MODEL 246.
ALL ELECTRICAL POWER SHOULD BE REMOVED WHEN CONNECTING OR DISCONNECTING WIRING.
THIS DEVICE SHOULD BE INSTALLED AND SERVICED BY QUALIFIED PERSONNEL.

Installation Instructions

WARNING

The Model 246 is not to be used with input voltages greater than those for which the unit was designed.

140VAC for Model A246
280VAC for Model B246

INSTALLATION

Connect the input power to the 8-pin socket, following the Model 246 pin diagram, pictured on the unit, and on this data sheet. Insert the Model 246 into the socket and apply power.

If the contacts do not transfer (*both LEDs-off*), check that all three phases are present and of the correct voltage. If power is correct, rotate the UNDER VOLTAGE adjustment counter-clockwise, and the OVER VOLTAGE adjustment clockwise, to widen the operating band.

If the contacts still do not transfer, remove power and reverse two of the three phase wires, at the socket (*phase rotation is reversed*). Re-apply the power. The contacts should transfer to provide a signal path between pins 1 & 8 (*both LEDs-off*).

NOTE: When installing the **Model 246 Monitor** in areas of high humidity or contamination, it is recommended that the base area and all exposed metal parts of the socket be coated liberally with a good quality silicon grease, such as Dow Corning DC-4 or DC-4X. Insert the unit into the socket and wipe off excess grease around the base. This will prevent the entrance of moisture and other contaminants into the base and socket areas.

ADJUSTMENT PROCEDURE

Set UNDER VOLTAGE level: Rotate the UNDER VOLTAGE adjustment pot clockwise, until the contacts transfer (*UNDER VOLTAGE LED-On*). Slowly turn the UNDER VOLTAGE adjustment counter-clockwise until the contacts reset (*UNDER VOLTAGE LED-Off*).

Set OVER VOLTAGE level: Turn the OVER VOLTAGE adjustment pot counter-clockwise, until the contacts transfer (*OVER VOLTAGE LED-On*). Slowly turn the OVER VOLTAGE adjustment pot clockwise until the contacts reset (*OVER VOLTAGE LED-Off*).

Nuisance tripping: The settings achieved by these adjustments (above), will be correct for most applications. Should nuisance tripping occur, turn the OVER VOLTAGE and the UNDER VOLTAGE adjustments slightly further, widening the operating band.

PIN DIAGRAM

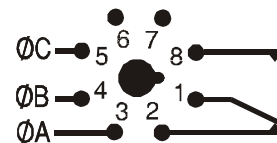

TROUBLESHOOTING

Should the Model 246 3-Phase Monitor fail to operate, check all connections. Verify that all three voltages are present, and check all fuses. Should problems persist, contact the factory for assistance.

WARRANTY

The **Model 246 3-Phase Monitor** is covered by Time Mark Corporation's exclusive **5-Year Unconditional Warranty**. Should this device fail, for any reason, within five years from the date of purchase, we will repair or replace it free. Contact the Time Mark Sales department, Monday through Friday; 8 a.m. to 5 p.m., CST, for further details.

Telephone: Main - (918) 438-1220
Sales - (800) 862-2875
Fax: (918) 437-7584

E-mail: sales@time-mark.com
Internet: http://www.time-mark.com



TIME MARK
CORPORATION

11440 East Pine Street
Tulsa, Oklahoma 74116

Doc No. 87A112 07/11
© 2011 TIME MARK CORPORATION

TIME MARK is a division of  AEMT, Inc.

MODEL 25

True RMS 3-Phase Monitor

- User selectable relay operation options
- Low or High Trip with independent delays or disabled
- User programmable
- Can be restored to factory settings or calibrated using a True RMS Voltmeter in the field

DESCRIPTION

Model 25 True RMS 3-Phase Monitor has a display that shows the voltage with an accuracy of +/- 0.5%. The display is updated every second and re-initialized every 30 seconds.

Model 25 has a rotary encoder with switch on the unit. By pressing the encoder switch for more than 5 seconds, the unit will enter the setup mode.

This unit has a user selectable relay option for High-Low or DPDT. It can also be user-selected to energize on fault or de-energize on fault. The user can select automatic or manual restart on the Model 25.

Model 25 True RMS 3-Phase Monitor can be either calibrated using a True RMS Voltmeter or can be restored to factory defaults in the field.

DIMENSIONS

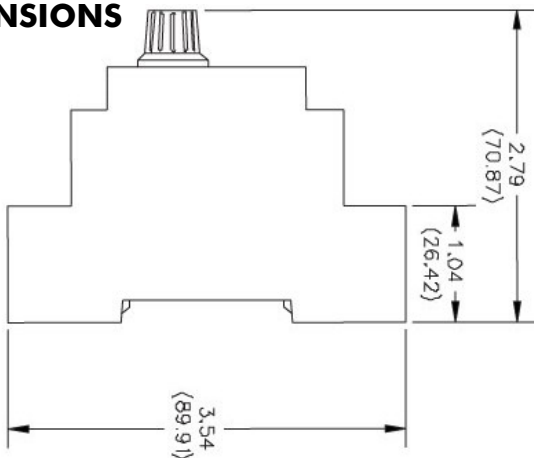

SPECIFICATIONS

Model	25
Upper AC Voltage Range	550 Volts
Lower AC Voltage Range	80 Volts
DC Power	24 Volts 2 watts
Start-up Delay	5 secs. Min. or Automatic reset delay setting (to allow for solid lock)
Frequency	50/60 Hz (400 Hz optional with jumper)
Output Contacts	SPDT x 2 10 Amps @ 240VAC
Repeat Accuracy	± 0.5 % (fixed conditions)
Reset Type	Manual or Automatic
Expected Relay Life	Mech: 10 million operations Elec: 100,000 min. at rated load
Operating Temp	-20°F to +130°F
Humidity Tolerance	0-97% w/o condensation
Enclosure Material	Lexan 920 Polycarbonate UL 94 V-0 1.5 mm UL E45329
Mounting	Din Rail 35mm
Weight	8.5 oz.

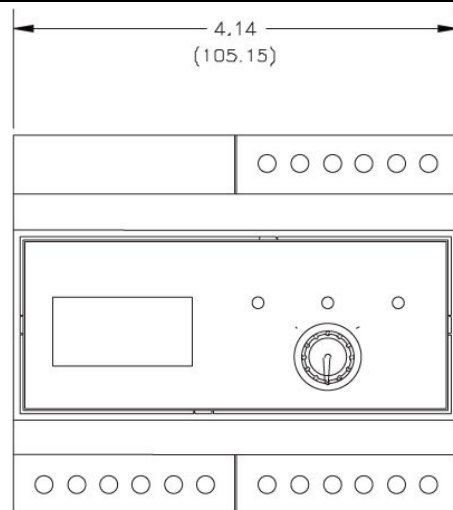

Telephone: Main - (918) 438-1220
Sales - (800) 862-2875
Fax: (918) 437-7584

E-mail: sales@time-mark.com
Internet: http://www.time-mark.com



TIME MARK
CORPORATION

11440 East Pine Street
Tulsa, Oklahoma 74116

Page 1 of 3 08/2011
© 2011 TIME MARK CORPORATION

TIME MARK is a division of  AEMT, Inc.

MODEL 25

True RMS 3-Phase Monitor

READ ALL INSTRUCTIONS BEFORE INSTALLING, OPERATING OR SERVICING THIS DEVICE.
KEEP THIS DATA SHEET FOR FUTURE REFERENCE.

GENERAL SAFETY

POTENTIALLY HAZARDOUS VOLTAGES ARE PRESENT AT THE TERMINALS OF THE MODEL 25.
ALL ELECTRICAL POWER SHOULD BE REMOVED WHEN CONNECTING OR DISCONNECTING WIRING.
THIS DEVICE SHOULD BE INSTALLED AND SERVICED BY QUALIFIED PERSONNEL.

Installation Instructions

INSTALLATION AND SETUP

Controls:

Rotary encoder with switch. Pressing the encoder switch will display the set points. Pressing the encoder switch for more than 5 seconds will enter the setup mode. Pressing switch displays the next menu item. Holding down the switch during setup mode will sequence through menus with 1 second intervals. Rotating the knob clockwise increases the value and counter-clockwise will decrease value.

For non-value options, rotating the knob either way will change the options on the display.

Setup Options:

(Press encoder for at least 5 seconds to enter setup)

High Voltage: (Factory—Enabled, Set point = 550V, Delay = 5S)

Enable/Disable:

(*If disabled set point and delay are skipped)

Set Point Range:

Low setpoint + 1 to 550V in 0.5V steps

High Trip Delay:

0 to 20.0 seconds in 0.1Sec steps

Low Voltage: (Factory—Enabled, Set point = 80V, Delay = 5S)

Enable/Disable:

(*If disabled set point and delay are skipped)

Set Point Range:

80 to High Setpoint - 1 in 0.5V steps

Low Trip Delay:

0 to 20.0 seconds in 0.1Sec steps

TYPICAL APPLICATION—DRAWING 1 MONITOR AND CONTROL

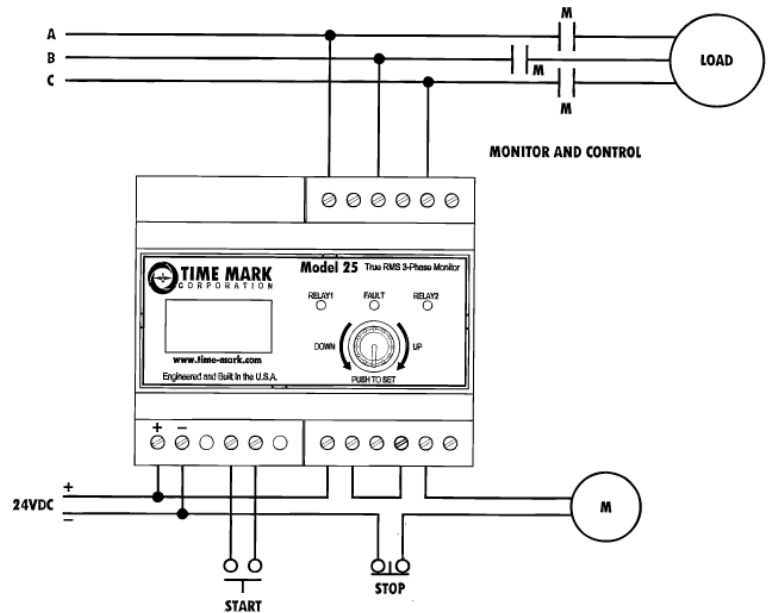

TYPICAL APPLICATION—DRAWING 2 MONITOR AND ALARMS

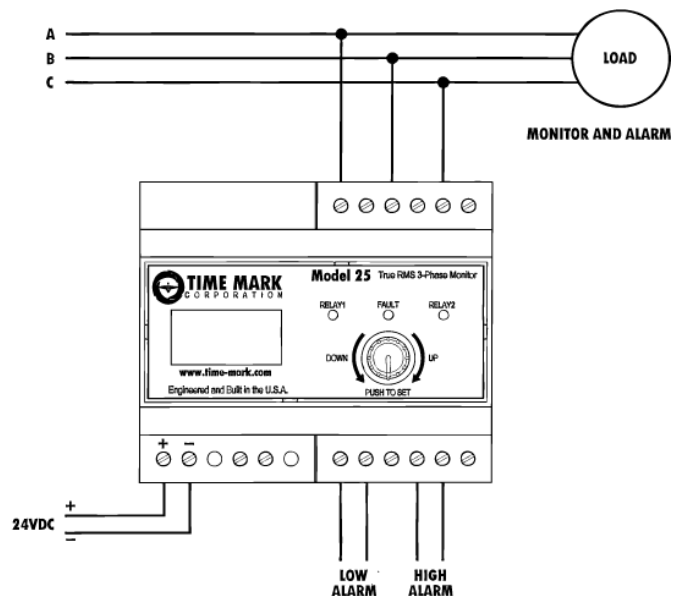

Telephone: Main - (918) 438-1220

Sales - (800) 862-2875

Fax: (918) 437-7584

E-mail: sales@time-mark.com

Internet: http://www.time-mark.com



TIME MARK
CORPORATION

11440 East Pine Street
Tulsa, Oklahoma 74116

Page 2 of 3 08/2011
© 2011 TIME MARK CORPORATION

TIME MARK is a division of  AEMT, Inc.

READ ALL INSTRUCTIONS BEFORE INSTALLING, OPERATING OR SERVICING THIS DEVICE.
KEEP THIS DATA SHEET FOR FUTURE REFERENCE.

GENERAL SAFETY

POTENTIALLY HAZARDOUS VOLTAGES ARE PRESENT AT THE TERMINALS OF THE MODEL 25.
ALL ELECTRICAL POWER SHOULD BE REMOVED WHEN CONNECTING OR DISCONNECTING WIRING.
THIS DEVICE SHOULD BE INSTALLED AND SERVICED BY QUALIFIED PERSONNEL.

Installation Instructions

INSTALLATION AND SETUP (Continued)

Relay Operation: (Factory = HI-LO)

Voltage High/Low Option:
Separate High/Low Relays
DPDT

Other faults DPDT

Relay Operation on Fault: (Factory - De-energize on fault)

De-energize on fault
Energize on fault
Hysteresis set
Unbalance set
Phase Loss set
Reverse Phase set

Restart: (Factory - Automatic)

Automatic or Manual (in Manual rotating the knob or closing an external switch will reset the unit)

Automatic Restart Delay Range: (Factory - 5S)

0 to 300.0 Seconds in 0.1Sec steps

Exit from Setup Options:

Repeat Setup:
Press encoder to begin setup from beginning.
(High Enable)

Exit & No Save:
Press encoder to exit setup. Any changes have been discarded.

Exit & Save:
Press encoder to exit setup and save changes.
Unit will begin using new settings.

INSTALLATION AND SETUP (Continued)

Start Up Delay:

5 Seconds Minimum or Automatic Restart Delay setting (to allow for solid lock).

UNIT FIELD RESTORE SETTINGS AND RECALIBRATION

- 1) From a powered down condition. Apply the 3-Phase voltage first.
- 2) Press and hold the Encoder switch while applying the DC power to the unit. As soon as the splash screen appears release the button. After the splash screen ends. The display will show "No Rest Fac". Rotate encoder to change option to "Yes" to restore factory settings. Press the Encoder switch.
- 3) The display will show the phase A-B voltage. Place a meter between phases A and B. Rotate encoder to change the reading on the display to be what is on the meter. When readings match (+/-0.5V) press the Encoder switch.
- 4) The display will show the phase B-C voltage. Place a meter between phases B and C. Rotate encoder to change the reading on the display to be what is on the meter. When readings match (+/-0.5V) press the Encoder switch.
- 5) The display will show the phase C-A voltage. Place a meter between phases C and A. Rotate encoder to change the reading on the display to be what is on the meter. When readings match (+/-0.5V) press the Encoder switch.
- 6) The unit will return to normal operation.

Telephone: Main - (918) 438-1220

Sales - (800) 862-2875

Fax: (918) 437-7584

E-mail: sales@time-mark.com

Internet: http://www.time-mark.com



TIME MARK
CORPORATION

11440 East Pine Street
Tulsa, Oklahoma 74116

Page 3 of 3 08/2011
© 2011 TIME MARK CORPORATION

TIME MARK is a division of  AEMT, Inc.



MODEL 2500 MODEL 2501

3-Phase Monitor

- Monitors for Phase Loss or Reversal, Low Voltage or Voltage Unbalance
- Automatic Reset
- Heavy Duty Output Contacts
- UL Listed to U.S. and Canadian Safety Standards



DESCRIPTION

The Models 2500 and 2501 3-Phase Monitors are designed to continuously monitor the voltages of a 3-phase power distribution system for abnormal conditions. The monitors feature solid-state voltage and phase angle sensing circuits which drive a SPDT electromechanical output relay. A neutral connection is **not** required with either the Model 2500 or 2501. This allows each model to be connected to any three phase WYE or DELTA configured power distribution system.

When the correct voltage and phase sequence is applied to a specified Model 2500, the output relay **will not energize**. An under voltage, phase reversal, phase unbalance or phase loss condition **will cause** the output relay to **energize**, even if regenerated voltage is present. Complete power loss **will not cause** Model 2500 to trip.

When the correct voltage and phase sequence is applied to a specified Model 2501, the output relay **will energize**. An under voltage, phase reversal, phase unbalance, or phase loss condition **will cause** the output relay to **de-energize**.

Each option on the Model 2500 or 2501 is adjustable throughout it's operating range. The adjustment pots and LED indicators for VOLTAGE ADJUST, UNBALANCE ADJUST and TIME DELAY are mounted on the front of the unit, for easy access.

Seven versions of both the Model 2500 and the Model 2501 cover voltage ranges from 120 to 600 VAC. All models are UL Listed to U.S. and Canadian safety standards.

SPECIFICATIONS

Model	2500-120 2501-120	2500-208 2501-208	2500-240 2501-240	2500-380 2501-380	2500-415 2501-415	2500-480 2501-480	2500-600 2501-600
Nominal AC Voltage	120	208	240	380	415	480	600
Adjustment Range	84-114V	146-198V	168-229V	266-361V	290-394V	336-456V	420-570V
Frequency	50/60 Hz						
Unbalance adj range	2 to 10% per NEMA specifications						
Trip Delay adj range	1 to 10 seconds (1 sec increments)						
Power Consumption	4.5W per phase						
Repeat Accuracy	± 1% of full scale						
Reset Time	150 msec nominal						
Reset Type	Automatic						
Dead Band	2% of full scale						
Output Contacts	SPDT 30 amps at 28VDC/300VAC 50/60 Hz 5 amps at 480/600VAC 50/60 Hz 0.75 PF						
Operating Temp	- 4° to +131° F						
Humidity Tolerance	0-97% without condensation						
Enclosure Material	ABS plastic						
Weight	2 lbs. 5 oz.						
Mounting	Surface						
Agency Approval	UL Listed to U.S. and Canadian safety standards						

TYPICAL APPLICATION - Motor

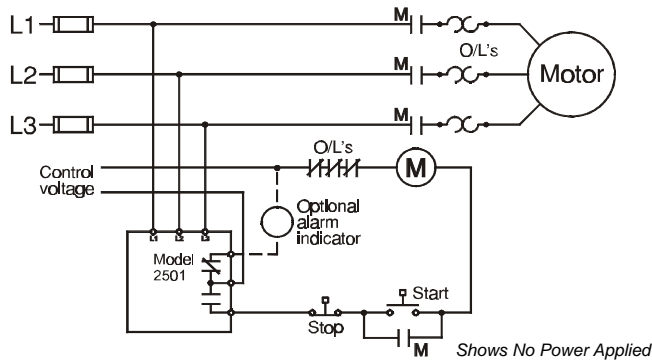

DIMENSIONS

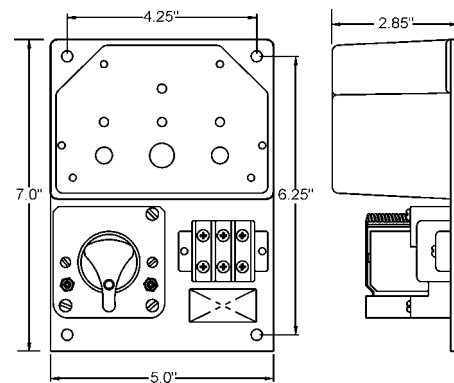

Telephone: Main - (918) 438-1220
Sales - (800) 862-2875
Fax: (918) 437-7584

E-mail: sales@time-mark.com
Internet: http://www.time-mark.com



TIME MARK
CORPORATION

11440 East Pine Street
Tulsa, Oklahoma 74116

Doc No. 87A429 12/00
© 2000 TIME MARK CORPORATION

TIME MARK is a division of  AEMT, Inc.

MODEL 2500 MODEL 2501 3-Phase Monitor

READ ALL INSTRUCTIONS BEFORE INSTALLING, OPERATING OR SERVICING THIS DEVICE.
KEEP THIS DATA SHEET FOR FUTURE REFERENCE.

Installation Instructions

DANGER

- HAZARD OF ELECTRIC SHOCK, BURN OR EXPLOSION
- POWER CONTROL & INSTRUMENT CIRCUITS MAY BE SUPPLIED BY REMOTE SOURCES
- THIS DEVICE SHOULD ONLY BE INSTALLED OR SERVICED BY QUALIFIED PERSONNEL
- TURN OFF ALL POWER SUPPLYING THIS DEVICE BEFORE WORKING ON MONITOR
- FAILURE TO DO SO WILL RESULT IN DEATH OR SEVERE PERSONAL INJURY

INSTALLATION

Mount the Model 2500 or 2501 in a stable location, observing all precautions outlined in the statement above. Mounting hardware is not included.

Connect the control wiring to the terminals with the contact markings (refer to the diagram on the unit). Markings shown on the unit are in the power off condition. Apply power.

If the contacts transfer (NORMAL indicator-Off), check the LOW, REVERSE, and UNBALANCE indicators for a possible fault condition. If no indicators are lit, check that all three phases are present and of the correct voltage.

If all phases are correct and the LOW indicator is ON, rotate the VOLTAGE ADJUST until the light just goes out.

If the UNBAL indicator is ON, rotate the UNBAL ADJUST until the light just goes out.

NOTE: During adjustment you may find the UNBAL ADJUST and the TRIP DELAY adjustment has no effect. Check for phase loss.

If the REVERSE indicator is ON, remove power and reverse any two of the three input wires and re-apply power. The contacts should transfer to the normal condition (normally-open contacts open, NORMAL indicator-ON).

ADJUSTMENT

Note: During adjustment, you may want to install a jumper across the control contacts or open circuit, depending on your control configuration, to prevent cycling the load on and off.

Rotate the VOLTAGE ADJUST to the desired percent of nominal voltage, or slowly clockwise, until the contacts transfer to the failed condition (LOW indicator-ON).

Slowly turn the adjustment counter-clockwise until the contacts reset to the normal condition (LOW indicator-OFF; NORMAL indicator-ON).

Remove the jumper from the control contacts, if installed.

This setting will be correct for most applications. If nuisance tripping occurs, turn the VOLTAGE ADJUST slightly counter-clockwise, or increase the trip delay time.

Any adjustments to the VOLTAGE ADJUST, to eliminate nuisance tripping, should be made in small increments, until the *true* nuisance trips are eliminated. Adjust the TRIP DELAY and UNBAL ADJUST as required by the system.

TYPICAL APPLICATION - Shunt Breaker

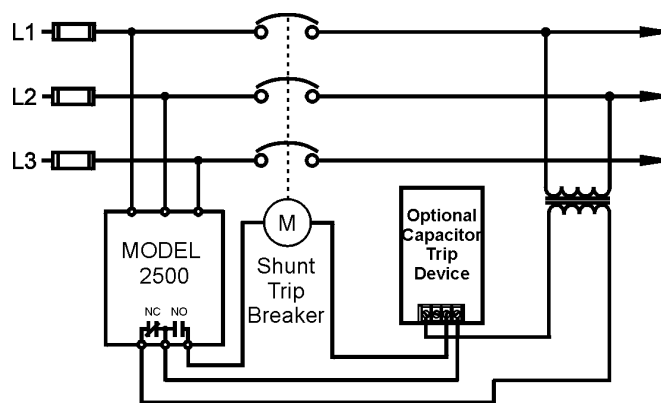

diagram shows no power applied

WARRANTY

The **Model 2500 and Model 2501 3-Phase Monitors** are covered by Time Mark Corporation's exclusive **5-Year Unconditional Warranty**. Should this device fail, for any reason, within five years from the date of purchase, we will repair or replace it free. Contact the Time Mark Sales department for further details.

Telephone: Main - (918) 438-1220
Sales - (800) 862-2875

Fax: (918) 437-7584

E-mail: sales@time-mark.com
Internet: http://www.time-mark.com



TIME MARK
CORPORATION

11440 East Pine Street
Tulsa, Oklahoma 74116

Doc No. 87A429 12/00
© 2000 TIME MARK CORPORATION

TIME MARK is a division of  AEMT, Inc.

MODEL 252

3-Phase Monitor

- Detects Phase Loss, Low Voltage and Phase Reversal
- 50 Hz and 60 Hz versions
- Automatic Reset

DESCRIPTION

The Model 252 3-Phase Monitor continuously monitors 3-phase power lines for abnormal conditions. When properly adjusted, the Model 252 will detect phase loss on a loaded motor even when regenerated voltage is present.

This device consists of a solid-state voltage and phase-angle sensing circuit, driving an electromechanical relay with one SPDT and one SPST contact. When correct voltage and phase rotation are applied, the internal relay will energize. A fault condition will de-energize the relay. When the fault is corrected the Model 252 will automatically reset.

The Model 252 does not require a neutral connection and can be used with WYE or DELTA configured systems. Four versions cover 120V, 208/240V and 480V, 60Hz, and 380V, 50Hz. Adjustment ranges are sufficiently wide to allow for proper adjustment to existing conditions. Two LED indicators are provided to aid in adjustment and system troubleshooting.

TYPICAL APPLICATION

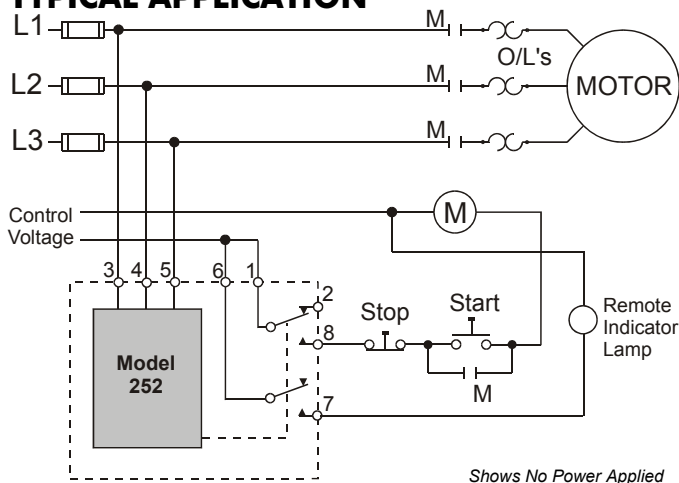

SPECIFICATIONS

Model	B252B	252B	A252B	EX252B
Nominal AC Voltage	120VAC	208/240VAC	480VAC	380VAC
Adjustment Range	85-120VAC	160-240VAC	380-480VAC	300-380VAC
Frequency	60 Hz			50Hz
Power Consumption	0.25 W	0.50 W	1.5 W	1.25 W
Transient Protection	2500V for 10 msec			
Repeat Accuracy	0.1% of set point (fixed conditions)			
Response Time	0.05 seconds			
Reset Time	0.05 seconds			
Reset Type	Automatic			
Dead Band	2%			
Output Contacts	1 - SPDT		1 - SPST (N.O.)	
Contact Rating	5A at 115VAC resistive			
Expected Relay Life	Mech: 10 million operations Elec: 100,000 at rated load			
Operating Temp	- 20° to 131° F			
Humidity Tolerance	97% w/o condensation			
Enclosure Material	ABS plastic			
Mounting	8-pin socket (*order separately)			
Weight	5 oz.			
Agency Approvals	UL Recognized (U.S. & Canadian)			

*Order 8-pin socket number 51X120

DIMENSIONS

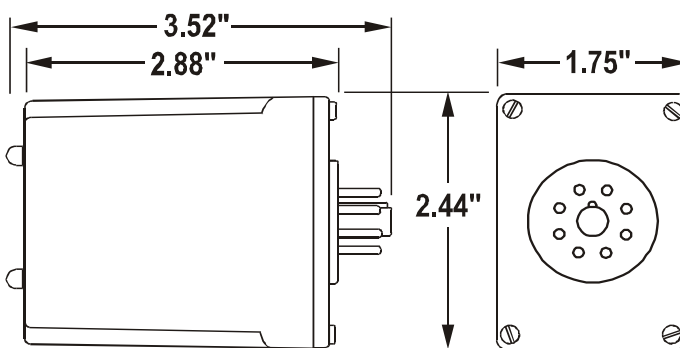

Telephone: Main - (918) 438-1220

Sales - (800) 862-2875

Fax: (918) 437-7584

E-mail: sales@time-mark.com

Internet: http://www.time-mark.com



TIME MARK
CORPORATION

11440 East Pine Street
Tulsa, Oklahoma 74116

Doc No. 87A373 07/2011
© 2011 TIME MARK CORPORATION

TIME MARK is a division of  AEMT, Inc.

MODEL 252

3-Phase Monitor

READ ALL INSTRUCTIONS BEFORE INSTALLING, OPERATING OR SERVICING THIS DEVICE.
KEEP THIS DATA SHEET FOR FUTURE REFERENCE.

GENERAL SAFETY

POTENTIALLY HAZARDOUS VOLTAGES ARE PRESENT AT THE TERMINALS OF THE MODEL 252.
ALL ELECTRICAL POWER SHOULD BE REMOVED WHEN CONNECTING OR DISCONNECTING WIRING.
THIS DEVICE SHOULD BE INSTALLED AND SERVICED BY QUALIFIED PERSONNEL.

Installation Instructions

INSTALLATION

Mount the socket in a suitable enclosure. A NEMA approved enclosure, designed for socket-mounted relays, is available from Time Mark Corporation.

Connect the 3-phase power to terminals 3, 4 and 5 on the socket. Phase rotation may be verified using a Time Mark Model 108A or 108B Phase Sequence Detector.

Connect the load control wiring to the appropriate terminals on the socket. The SPST contacts (pins 6 and 7) are electrically isolated from the SPDT contacts.

For motor control and phase loss alarm applications; use the SPDT contacts.

For auxiliary indicator applications; use the appropriate SPST contacts.

Insert the Model 252 into the socket.

Apply power. If the contacts do not transfer, (TRIP indicator-On), check that all phases are present and of the correct voltage. If power is correct, rotate the level adjustment counter-clockwise.

If the contact still does not transfer, remove power and reverse two of the three phase wires at the socket (phase rotation is reversed). Re-apply power. The contact should transfer to provide a signal path between both sets of normally-open contacts. The green LED (NORMAL) should be lit.

Note: When installing the Model 252 in areas of high humidity or contamination, it is recommended that the base area and all exposed metal parts of the socket be coated liberally with a good quality silicon grease, such as Dow Corning DC-4 or DC-4X. Insert the unit into the socket and wipe off excess grease around the base. This will prevent the entrance of moisture and other contaminants into the base and socket area.

PIN DIAGRAM

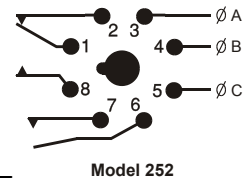

ADJUSTMENT

The following procedure will adjust the Model 252 to trip below the nominal voltage.

Rotate the level adjustment clockwise, until the relay contact transfers (TRIP indicator On). Slowly turn the adjustment counter-clockwise, until the contact resets. This setting will be correct for most applications.

Should nuisance tripping occur, turn the adjustment slightly farther counter-clockwise, lowering the trip level. A more accurate adjustment procedure requires a 3-phase variac, allowing the voltage to be lowered to a specific voltage. The Model 252 can then be set to trip at this precise voltage level, when installed in the motor control circuit. Factory set versions are also available.

TROUBLESHOOTING

Should the Model 252 fail to operate properly, check that all three voltages are present and are of the correct level and phase rotation (a Model 108A or 108B Phase Sequence Detector may be used to verify phase rotation). Check all fuses and verify that all wiring connections are correct. Should problems persist, contact the manufacturer at 800-862-2875.

WARRANTY

The **Model 252 3-Phase Monitor** is covered by Time Mark Corporation's exclusive **5-Year Unconditional Warranty**. Should this device fail, for any reason, within five years from the date of purchase, we will repair or replace it, free. Contact the Time Mark Sales department for further information.

Telephone: Main - (918) 438-1220

Sales - (800) 862-2875

Fax: (918) 437-7584

E-mail: sales@time-mark.com

Internet: http://www.time-mark.com



TIME MARK
CORPORATION

11440 East Pine Street
Tulsa, Oklahoma 74116

Doc No. 87A373 07/2011
© 2011 TIME MARK CORPORATION

TIME MARK is a division of  AEMT, Inc.

MODEL 2522

3-Phase Monitor



- Detects Phase Loss, Low Voltage, Phase Reversal
- Automatic or Manual Reset
- DPDT Relay Output



DESCRIPTION

The **Model 2522** continuously monitors 3-phase power lines for abnormal conditions. When properly adjusted, the Model 2522 will detect phase loss on a loaded motor even when regenerated voltage is present.

This unit consists of a solid-state voltage and phase-angle sensing circuit, driving an electromechanical relay with DPDT contacts. When correct voltage and phase rotation are applied, the internal relay will energize. A fault condition will de-energize the relay. When the fault is corrected the Model 2522 will reset.

Both automatic and manual reset versions are available. The Model 2522 does not require a neutral connection, and can be used with Wye or Delta systems. Adjustment ranges are sufficiently wide to allow for proper adjustment to existing conditions. A failure indicator is provided to aid in adjustment and system troubleshooting.

SPECIFICATIONS

AUTO Reset	B2522B	2522B
MANUAL Reset	B2522BM	2522BM
Nominal Voltage	120 VAC	208/240 VAC
Max Input Voltage	132 VAC	262 VAC
Adjustment Range	85-120 VAC	160-240 VAC
Frequency	60 Hz	60 Hz
Power Consumption	.75 W	1.5 W
Transient Protection	2500 VRMS for 10ms	
Repeat Accuracy	±0.1% of set-point (fixed conditions)	
Response Time	0.05 seconds	
Reset Time	0.05 seconds	
Reset Type	Automatic or Manual	
Dead Band	2%	
Contact Rating	DPDT 5 amps , 115 VAC resistive	
Max. Contact Rating	870 VA, 30 VDC, 300 VAC	
Expected Relay Life	Mech: 10 million operations Elec: 100,000 operations at rated load	
Operating Temp	- 20° to +131° F	
Humidity Tolerance	97% w/o condensation	
Enclosure Material	ABS plastic	
Mounting	*11-pin socket (order separately)	
Weight	5 oz.	

*Order socket number 51X016

TYPICAL APPLICATION

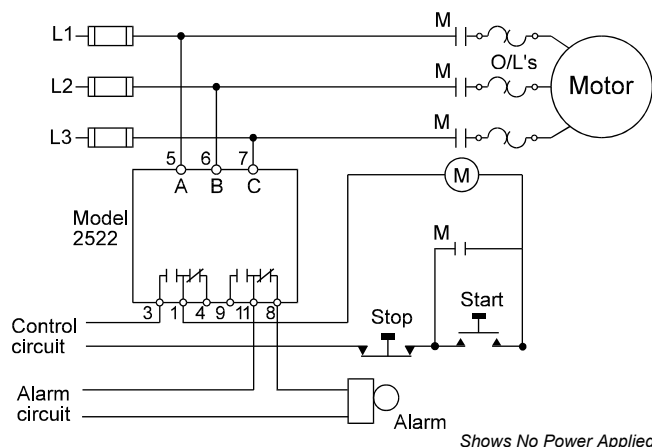

DIMENSIONS

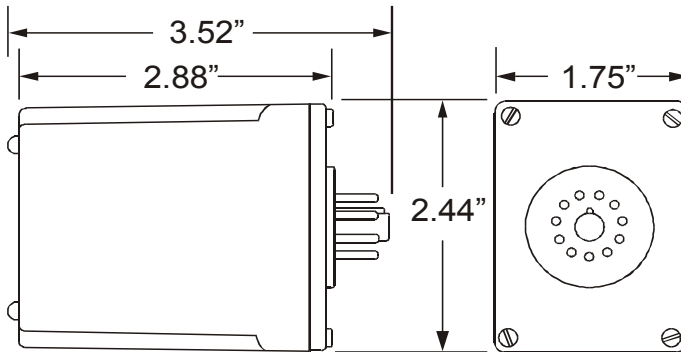

(dimensions have tolerance of ± 0.06)

Telephone: Main - (918) 438-1220

Sales - (800) 862-2875

Fax: (918) 437-7584

E-mail: sales@time-mark.com

Internet: http://www.time-mark.com



TIME MARK
CORPORATION

11440 East Pine Street
Tulsa, Oklahoma 74116

Doc No. 87A382 07/2011
© 2011 TIME MARK CORPORATION

TIME MARK is a division of  AEMT, Inc.

MODEL 2522 3-Phase Monitor

READ ALL INSTRUCTIONS BEFORE INSTALLING, OPERATING OR SERVICING THIS DEVICE.
KEEP THIS DATA SHEET FOR FUTURE REFERENCE.

GENERAL SAFETY

POTENTIALLY HAZARDOUS VOLTAGES ARE PRESENT AT THE TERMINALS OF THE MODEL 2522.
ALL ELECTRICAL POWER SHOULD BE REMOVED WHEN CONNECTING OR DISCONNECTING WIRING.
THIS DEVICE SHOULD BE INSTALLED AND SERVICED BY QUALIFIED PERSONNEL.

Installation Instructions

INSTALLATION

Mount the 11-pin socket in a suitable enclosure.

Connect 3-phase power to terminals 5, 6 and 7 on the socket. Phase rotation may be verified using a Time Mark Model 108A or 108B Phase Sequence Detector.

Connect the load control wiring to the appropriate terminals on the socket:

For motor control applications; use terminals 1 and 3.
For phase loss alarm applications; use terminals 11 and 8.

Insert the Model 2522 into the socket and apply power.

If the contacts do not transfer, (green light ON), check that all phases are present and of the correct voltage. If power is correct, rotate the level adjustment counter-clockwise (CCW). If the contact still does not transfer, remove power and reverse any two of the three phase wires at the socket (phase rotation is reversed).

Re-apply power. The contact should transfer to provide a signal path between pins 1 and 3 and pins 9 and 11. The green LED should be lit.

NOTE: When installing the Model 2522 monitor in areas of high humidity or contamination, it is recommended that the base area and all exposed metal parts of the socket be coated liberally with a good quality silicon grease, such as Dow Corning DC-4 or DC-4X. Insert the unit into the socket and wipe off excess grease around the base. This will prevent the entrance of moisture and other contaminants into the base and socket areas.

ADJUSTMENT SETTINGS

The following procedure will allow the Model 2522 to be adjusted to achieve a trip point just below the nominal phase-to-phase voltage, where the unit is applied. **On manual reset versions**, hold the reset button down during the following procedure.

Rotate the adjustment control fully clockwise, or until the red (TRIP) indicator illuminates.

Slowly rotate the adjustment control in a counter clockwise direction, just until the green (NORM) indicator illuminates.

At this point, the Model 2522 is the most sensitive to irregular power line conditions. If nuisance tripping occurs, turn the control slightly farther counter-clockwise.

A more accurate setting will require the use of a 3-phase variac to lower the voltage to an exact measurable setting. Time Mark offers a factory set versions of all models and voltage ranges, for only a small additional charge.

PIN DIAGRAMS

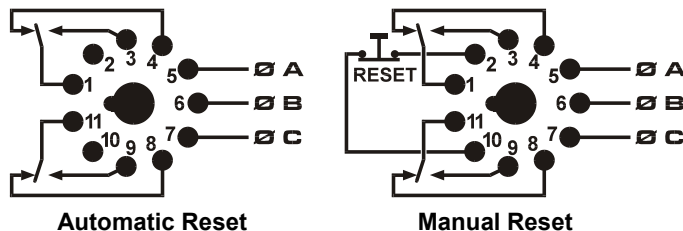

TROUBLESHOOTING

Should the Model 2522 fail to operate properly, check that all three voltages are present and are of the correct voltage level and phase rotation (a Model 108A or 108B phase sequence detector may be used to verify phase rotation). Check all fuses and verify that all wiring connections are correct. If problems persist, contact your local Time Mark Distributor, or the manufacturer at 800-862-2875.

WARRANTY

The **Model 2522 3-Phase Monitor** is warranted to be free from defects in materials and workmanship, and is covered by our exclusive **5-year Unconditional Warranty**. If this device fails to operate, for any reason, we will repair or replace it free, for five years from the date of purchase. Contact your local Distributor or the Time Mark Sales department, Monday through Friday; 8 a.m. to 5 p.m., CST, for further details.

Telephone: Main - (918) 438-1220
Sales - (800) 862-2875
Fax: (918) 437-7584

E-mail: sales@time-mark.com
Internet: http://www.time-mark.com



11440 East Pine Street
Tulsa, Oklahoma 74116

Doc No. 87A382 07/2011
© 2011 TIME MARK CORPORATION

TIME MARK is a division of  AEMT, Inc.

MODEL 253

Reverse Phase Relay

- Socket-mounted
- Senses phase reversal
- Low power consumption
- UL Recognized; CSA Certified



DESCRIPTION

The **Model 253 Reverse Phase Relay** is a solid-state sensing device designed for installation in equipment using 3-phase power. This unit is used where it is desirable to have a contact closure indicating that the proper phase rotation sequence has been applied.

The relay closes when the proper sequence (**A B C**) is applied, but will remain open if any two phases are reversed. If reverse phasing occurs during operation, the relay also de-energizes.

The Model 253 has a special industrial grade relay designed for low power consumption. The **A B C** indicator will be illuminated when the proper phase rotation sequence is applied.

SPECIFICATIONS

Model	253
Nominal voltage	208 - 480 VAC (phase to phase)
Operating range	190 - 480 VAC
Frequency	50 to 60 Hz
Power consumption	2W per phase
Transient protection	2500V for 10 msec
Repeat accuracy	± 0.1% (fixed conditions)
Response time	.05 seconds
Reset time	.05 seconds
Reset type	Automatic
Dead Band	Approximately 2%
Output contacts	SPDT 10A at 240 VAC resistive
Expected relay life	Mechanical: 10 million operations Electrical: 100,000 at rated load
Operating temperature	- 20° to +131° F
Humidity tolerance	0 - 97% w/o condensation
Case material	ABS plastic
Mounting	8-pin socket *(order separately)
Weight	6 oz.
Agency approval	UL Recognized and CSA Certified

* Order 8-pin socket number 51X120

DIMENSIONS

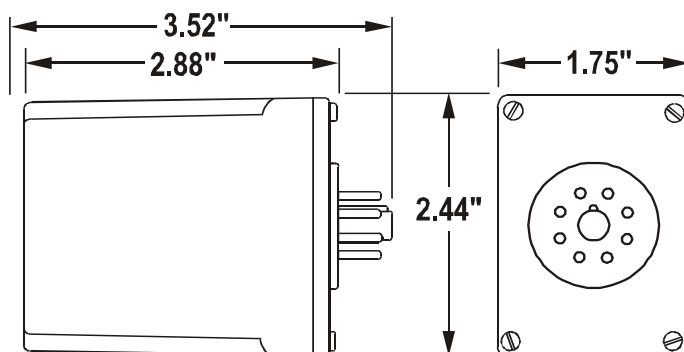

(dimensions have tolerance of ± 0.06)

Telephone: Main - (918) 438-1220
Sales - (800) 862-2875
Fax: (918) 437-7584

E-mail: sales@time-mark.com
Internet: http://www.time-mark.com



11440 East Pine Street
Tulsa, Oklahoma 74116

Doc No. 87A113 07/11
© 2011 TIME MARK CORPORATION

TIME MARK is a division of  AEMT, Inc.

MODEL 253 Reverse Phase Relay

READ ALL INSTRUCTIONS BEFORE INSTALLING, OPERATING OR SERVICING THIS DEVICE.
KEEP THIS DATA SHEET FOR FUTURE REFERENCE.

GENERAL SAFETY

POTENTIALLY HAZARDOUS VOLTAGES ARE PRESENT AT THE TERMINALS OF THE MODEL 253.
ALL ELECTRICAL POWER SHOULD BE REMOVED WHEN CONNECTING OR DISCONNECTING WIRING.
THIS DEVICE SHOULD BE INSTALLED AND SERVICED BY QUALIFIED PERSONNEL.

Installation Instructions

WARNING

IN APPLICATIONS WHERE VOLTAGES IN EXCESS OF 300 VAC ARE TO BE MONITORED, BE CERTAIN TO USE THE TIME MARK MODEL 51X120 8-PIN SOCKET, OR AN EQUIVALENT UL APPROVED 600 VAC RATED SOCKET.

INSTALLATION

Refer to the Pin Drawing below, and on the case of the Model 253. The contacts are shown in the tripped condition.

Connect wiring to the socket as shown (an 8-pin socket, rated for at least 480 VAC is required).

Refer to the Application Drawing for additional information.

PIN DRAWING

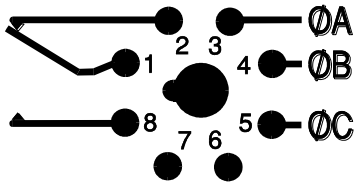

If the relay contacts do not transfer when power is applied (indicator not lit), check that all three voltages are correct. If power is present and of the correct voltage, remove power, then reverse two of the three phase connections at the socket.

Re-apply power. The contacts should transfer to the normal condition (pins 1 and 8 closed; indicator lit). There are no calibrations or adjustments required.

NOTE: When installing the Model 253 monitor in areas of high humidity or contamination, it is recommended that the base area and all exposed metal parts of the socket be coated liberally with a good quality silicon grease, such as Dow Corning DC-4 or DC-4X. Insert the unit into the socket and wipe off excess grease around the base. This will prevent the entrance of moisture and other contaminants into the base and socket areas.

TROUBLESHOOTING

Should the relay fail to operate properly, check that all three voltages are present and are of the correct level. Check all fuses and verify that all wiring connections are correct. Should problems persist, contact the factory for assistance.

TYPICAL APPLICATION

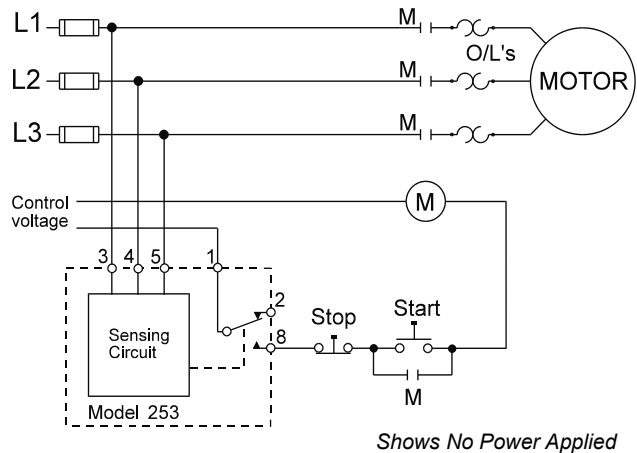

WARRANTY

The **Model 253 Reverse Phase Relay** is covered by Time Mark Corporation's exclusive **5-Year Unconditional Warranty**. Should this device fail, for any reason, within five years from the date of purchase, we will repair or replace it. Contact the Time Mark Sales department, Monday through Friday; 8 a.m. to 5 p.m., CST, for further details.

Telephone: Main - (918) 438-1220
Sales - (800) 862-2875
Fax: (918) 437-7584

E-mail: sales@time-mark.com
Internet: http://www.time-mark.com



11440 East Pine Street
Tulsa, Oklahoma 74116
Doc No. 87A113 07/11
© 2011 TIME MARK CORPORATION

TIME MARK is a division of  AEMT, Inc.

MODEL 2532

Reverse Phase Relay

- Senses phase reversal on Wye or Delta
- 190 to 500 VAC range
- Machine tool case
- UL Recognized & CSA Certified



DESCRIPTION

The **Model 2532 Reverse Phase Relay** is designed to continuously monitor phase rotation of 3-phase lines. This device should be used in applications where proper phase rotation is critical, such as fan motors, compressors, grinders, elevators, etc.

The solid-state sensing circuit drives an internal electromechanical relay which energizes when power, *with correct phase rotation*, is applied.

The relay will not energize if the applied phases are reversed. It will de-energize if phase rotation is reversed while the motor is running. An LED indicator will illuminate with correct A B C phase rotation.

SPECIFICATIONS

Model	2532
Nominal voltage	190-500 VAC (phase to phase)
Frequency	50 to 60 Hz
Power Consumption	2W per phase
Transient protection	2500 VRMS for 10 msec
Repeat accuracy	± 0.1 % (fixed conditions)
Response time	.05 seconds
Reset time	.05 seconds
Reset type	Automatic
Dead band	Approximately 2 %
Output contacts	SPDT 10A at 240 VAC resistive
Expected relay life	Mechanical: 10 million operations Electrical: 100,000 at rated load
Operating temp	- 20° to +131° F
Humidity tolerance	0-97 % w/o condensation
Case material	ABS plastic
Mounting	Surface
Weight	7 oz.
Agency approval	UL Recognized and CSA Certified

DIMENSIONS

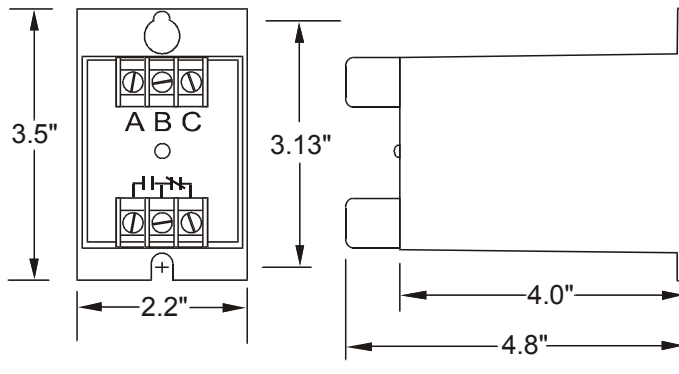

Telephone: Main - (918) 438-1220
Sales - (800) 862-2875
Fax: (918) 437-7584

E-mail: sales@time-mark.com
Internet: http://www.time-mark.com



11440 East Pine Street
Tulsa, Oklahoma 74116

Doc No. 87A149 07/2011
© 2011 TIME MARK CORPORATION

TIME MARK is a division of  AEMT, Inc.

MODEL 2532 Reverse Phase Relay

READ ALL INSTRUCTIONS BEFORE INSTALLING, OPERATING OR SERVICING THIS DEVICE.
KEEP THIS DATA SHEET FOR FUTURE REFERENCE.

GENERAL SAFETY

POTENTIALLY HAZARDOUS VOLTAGES ARE PRESENT AT THE TERMINALS OF THE MODEL 2532.
ALL ELECTRICAL POWER SHOULD BE REMOVED WHEN CONNECTING OR DISCONNECTING WIRING.
THIS DEVICE SHOULD BE INSTALLED AND SERVICED BY QUALIFIED PERSONNEL.

Installation Instructions

INSTALLATION

Mount the Model 2532 in the desired location.

Connect the 3-phase power to the terminals marked **A**, **B**, and **C**.

Connect the control circuit to the terminals with the contact markings. Refer to the Typical Application wiring diagram for additional information.

If the relay contacts do not transfer when power is applied (LED indicator-Off), check that all three voltages are correct.

If power is present and the voltage is correct, remove power. Reverse two of the three phase connections. Re-apply power.

The contacts should transfer to the normal condition (normally open contacts closed; LED indicator-On). Calibrations or adjustments are not required.

TROUBLESHOOTING

Should the relay fail to operate properly, check that all three voltages are present and are of the correct level. Check all fuses and verify that all wiring connections are correct. Should problems persist, contact the factory for assistance.

TYPICAL APPLICATION

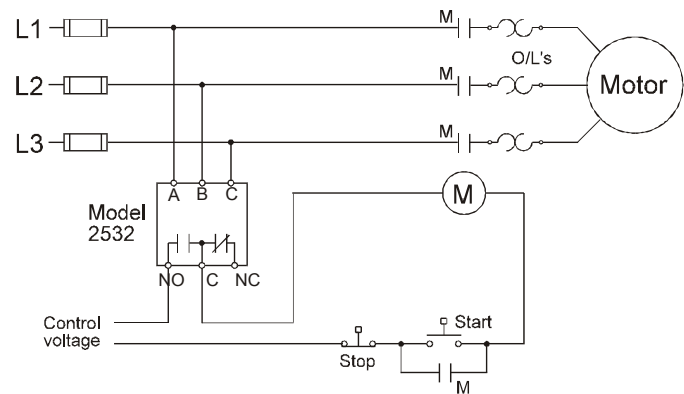

WARRANTY

The **Model 2532 Reverse Phase Relay** is covered by Time Mark Corporation's exclusive **5-Year Unconditional Warranty**. Should this device fail, for any reason, within five years from the date of purchase, we will repair or replace it. Contact the Time Mark Sales department, Monday through Friday; 8 a.m. to 5 p.m., CST, for further details.

Telephone: Main - (918) 438-1220

Sales - (800) 862-2875

Fax: (918) 437-7584

E-mail: sales@time-mark.com

Internet: <http://www.time-mark.com>



TIME MARK
CORPORATION

11440 East Pine Street
Tulsa, Oklahoma 74116

Doc No. 87A149 07/2011
© 2011 TIME MARK CORPORATION

TIME MARK is a division of  **AEMT, Inc.**

MODEL 257

3-Phase Monitor

- Detects phase loss, low voltage, phase reversal
- 50 Hz, 60 Hz and 400 Hz models
- Automatic or manual reset
- Five year unconditional warranty



DESCRIPTION

The **Model 257** continuously monitors 3-phase power lines for abnormal conditions. When properly adjusted, the Model 257 monitor will detect phase loss on a loaded motor even when regenerated voltage is present.

This device consists of a solid-state voltage and phase-angle sensing circuit, driving an electro-mechanical relay. When correct voltage and phase rotation are applied, the internal relay will energize. A fault condition will de-energize the relay. When the fault is corrected, the monitor will automatically reset (*a manual reset version is also available*).

The Model 257 does not require a neutral connection and can be used with Wye or Delta systems. Voltage ranges are sufficiently wide to allow for proper adjustment to existing conditions. Both "TRIP" and "NORM" condition indicators are provided to aid in adjustment and system trouble-shooting.



SPECIFICATIONS

AUTO Reset MANUAL Reset	B257B B257BM	257B 257BM	A257B A257BM	EX257B EX257BM	B257B-400 B257BM-400	257B-400 257BM-400
Nominal AC voltage (phase to phase)	120 vac	208/240 vac	480 vac	380 vac	120 vac	208/240 vac
Case Color	Gray	Red	Yellow	Yellow	Gray	Red
Adjustment range	85-120vac	160-240vac	380-480vac	300-400vac	85-120vac	160-240vac
Frequency	60 Hz	60 Hz	60 Hz	50 Hz	400 Hz	400 Hz
Power consumption	0.75W	1.5W	4.5W	3.75W	0.75W	1.5W
Transient protection	2500 VAC for 10msec					
Repeat accuracy	± 0.1% of set point (fixed conditions)					
Response time	50 msec (set or reset)					
Dead band	Approximately 2%					
Output contacts	SPDT 10 amps at 240 VAC resistive					
Expected relay life	Mechanical: 10 million operations Electrical: 100,000 operations at rated load					
Operating temp	-20° to +131° F					
Humidity tolerance	0 - 97% w/o condensation					
Enclosure material	Dust cover: ABS plastic					
Mounting	8-pin socket (**sold separately)					
Weight	5 ounces					
Agency approvals	UL Recognized* and CSA Certified *condition of acceptability: the 380V and 480V versions must be used with a UL Recognized 600 VAC socket					

** Order 8-pin socket number 51X120

TYPICAL APPLICATION

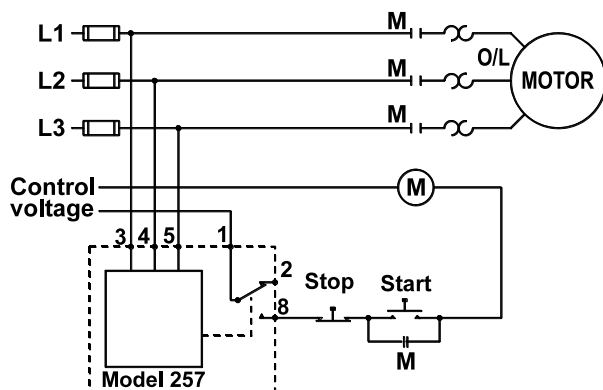

DIMENSIONS

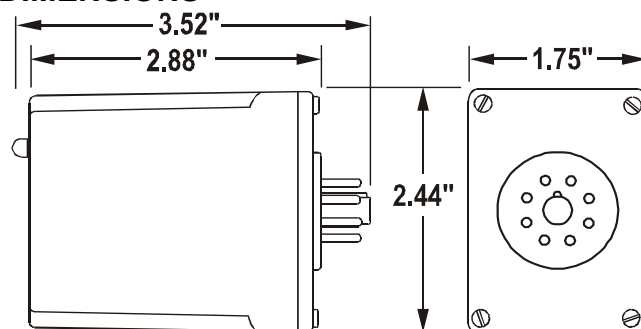

(dimensions have tolerance of ± 0.06)

Telephone: Main - (918) 438-1220

Sales - (800) 862-2875

Fax: (918) 437-7584

E-mail: sales@time-mark.com

Internet: http://www.time-mark.com



TIME MARK
CORPORATION

11440 East Pine Street
Tulsa, Oklahoma 74116

Doc No. 87A189 07/2011
© 2011 TIME MARK CORPORATION

TIME MARK is a division of  AEMT, Inc.

MODEL 257

3-Phase Monitor

READ ALL INSTRUCTIONS BEFORE INSTALLING, OPERATING OR SERVICING THIS DEVICE.
KEEP THIS DATA SHEET FOR FUTURE REFERENCE.

GENERAL SAFETY

POTENTIALLY HAZARDOUS VOLTAGES ARE PRESENT AT THE TERMINALS OF THE MODEL 257.
ALL ELECTRICAL POWER SHOULD BE REMOVED WHEN CONNECTING OR DISCONNECTING WIRING.
THIS DEVICE SHOULD BE INSTALLED AND SERVICED BY QUALIFIED PERSONNEL.

Installation Instructions

WARNING

IN APPLICATIONS WHERE VOLTAGES IN EXCESS OF 300 VAC ARE TO BE MONITORED, BE CERTAIN TO USE THE TIME MARK MODEL 51X120 8-PIN SOCKET, OR AN EQUIVALENT UL APPROVED 600 VAC RATED SOCKET.

INSTALLATION

Mount the 8-pin socket in a suitable enclosure. A NEMA-1 rated enclosure, designed for socket-mounted relays is available from Time Mark Corporation.

Connect 3-phase power to terminals 3, 4, and 5 on the socket. Phase rotation should be verified using a Time Mark Model 108A or 108B Phase Sequence Detector.

Connect the load control wiring to the appropriate terminals on the socket:

For motor control applications; use terminals 1 and 8.

For phase loss alarm applications; use terminals 1 and 2.

Insert the Model 257 into the socket and apply power. If the contact does not transfer (green light ON), check that all phases are present, and of the correct voltage. If power is correct, rotate the level adjustment counter-clockwise.

If the contact still does not transfer, remove power and reverse two of the three phase wires at the socket (*phase rotation is reversed*). Re-apply power. The contact should transfer to provide a signal path between pins 1 and 8.

NOTE: When installing the Model 257 monitor in areas of high humidity or contamination, it is recommended that the base area and all exposed metal parts of the socket be coated liberally with a good quality silicon grease, such as Dow Corning DC-4 or DC-4X. Insert the unit into the socket and wipe off excess grease around the base. This will prevent the entrance of moisture and other contaminants into the base and socket areas.

ADJUSTMENT SETTINGS

The following procedure will allow the Model 257 to be adjusted to achieve a trip point just below the nominal phase-to-phase voltage, where the unit is applied.

Rotate the adjustment control fully clockwise, or until the red (TRIP) indicator illuminates.

Slowly rotate the adjustment control in a counter-clockwise direction, just until the green (NORM) indicator illuminates.

At this point, the Model 257 is the most sensitive to irregular power line conditions. If nuisance tripping occurs, turn the control slightly farther counter-clockwise.

A more accurate setting will require the use of a 3-phase variac to lower the voltage to an exact measurable setting. Time Mark also offers a factory set version of all models and voltage ranges, for only a small additional charge.

TROUBLESHOOTING

Should the Model 257 Monitor fail to operate properly, check that all three voltages are present, and are of the correct voltage level and phase rotation (a Model 108A or 108B Phase Sequence Detector should be used to verify phase rotation). Check all fuses and verify that all wiring connections are correct. If problems persist, contact your local Time Mark Distributor, or the factory for assistance (*Monday-Friday, 8 a.m. to 5 p.m. CST*).

MANUAL RESET VERSIONS

IF YOU DO NOT WISH TO USE THE EXTERNAL RESET SWITCH ON THE MANUAL RESET VERSION, YOU MUST JUMPER PINS 6 AND 7. Refer to the Manual Reset 8-pin diagram.

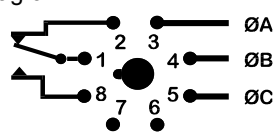

Automatic Reset

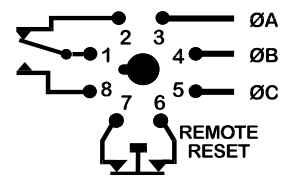

Manual Reset

WARRANTY

The **Model 257 3-Phase Monitor** is warranted to be free from defects in materials and workmanship, and is covered by our exclusive **5-year Unconditional Warranty**. If this device fails to operate, for any reason, we will repair or replace it free, for five years from the date of purchase. Contact the Time Mark Sales department, Monday through Friday; 8 a.m. to 5 p.m., CST, for further details.

Telephone: Main - (918) 438-1220
Sales - (800) 862-2875
Fax: (918) 437-7584

E-mail: sales@time-mark.com
Internet: http://www.time-mark.com



TIME MARK
CORPORATION

11440 East Pine Street
Tulsa, Oklahoma 74116
Doc No. 87A189 07/2011
© 2011 TIME MARK CORPORATION

TIME MARK is a division of  **AEMT, Inc.**

MODEL 258

3-Phase Monitor

- Detects phase loss, low voltage, phase reversal
- 50 Hz, 60 Hz and 400 Hz models
- Automatic or manual reset
- Five year unconditional warranty



DESCRIPTION

The **Model 258** continuously monitors 3-phase power lines for abnormal conditions. When properly adjusted, the Model 258 Monitor will detect phase loss on a loaded motor even when regenerated voltage is present.

This device consists of a solid-state voltage and phase-angle sensing circuit, driving an electro-mechanical relay. When correct voltage and phase rotation are applied, the internal relay will energize. A fault condition will de-energize the relay. When the fault is corrected, the monitor will automatically reset (*a manual reset version is also available*).

The Model 258 3-Phase Monitor does not require a neutral connection and can be used with Wye or Delta systems. Voltage ranges are sufficiently wide to allow for proper adjustment to existing conditions. Both "TRIP" and "NORM" condition indicators are provided to aid in adjustment and system troubleshooting.

SPECIFICATIONS

AUTO Reset MANUAL Reset	B258B B258BM	258B 258BM	A258B A258BM	EX258B EX258BM	B258B-400 B258BM-400	258B-400 258BM-400
Nominal AC voltage (phase to phase)	120 vac	208/240 vac	480 vac	380 vac	120 vac	208/240 vac
Case Color	Gray	Red	Yellow	Yellow	Gray	Red
Adjustment range	85-120 vac	160-240 vac	380-480 vac	300-400 vac	85-120 vac	160-240 vac
Frequency	60 Hz	60 Hz	60 Hz	50 Hz	400 Hz	400 Hz
Pwr consumption	0.75W	1.5W	4.5W	3.75W	0.75W	1.5W
Transient protection	2500 VAC for 10 ms					
Repeat accuracy	± 0.1% of set point (fixed conditions)					
Response time	50 msec (set or reset)					
Dead band	Approx. 2%					
Output contacts	SPDT 10 amps at 240 VAC resistive					
Expected relay life	Mechanical: 10 million operations Electrical: 100,000 operations at rated load					
Operating temp.	-20° to +131° F					
Humidity tolerance	0 - 97% w/o condensation					
Enclosure material	Dust cover: ABS plastic					
Mounting	8-pin socket (**sold separately)					
Weight	5 oz.					
Agency approvals	UL Recognized* and CSA Certified *condition of acceptability: the 380V and 480V versions must be used with a UL Recognized 600 VAC socket					

** Order 8-pin socket number 51X120

TYPICAL APPLICATION

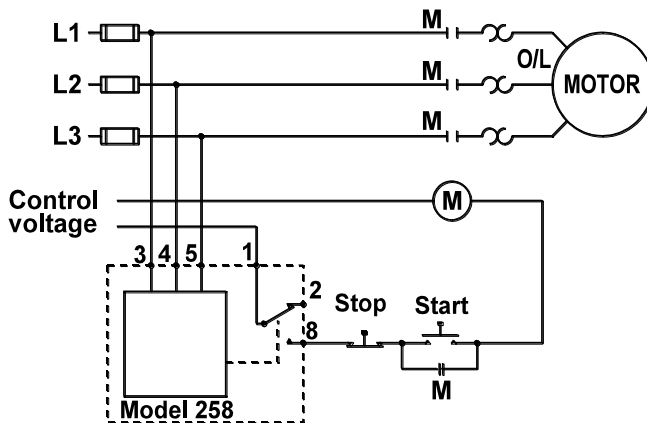

DIMENSIONS

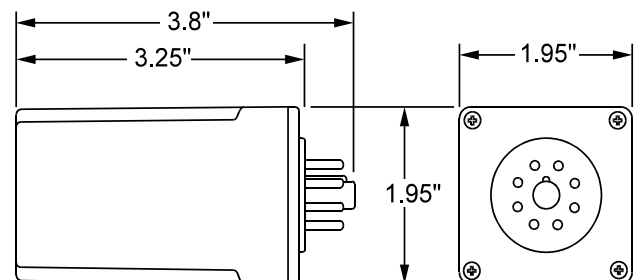

Telephone: Main - (918) 438-1220

Sales - (800) 862-2875

Fax: (918) 437-7584

E-mail: sales@time-mark.com

Internet: http://www.time-mark.com



TIME MARK
CORPORATION

11440 East Pine Street
Tulsa, Oklahoma 74116

Doc No. 87A123 07/2011
© 2011 TIME MARK CORPORATION

TIME MARK is a division of  AEMT, Inc.

MODEL 258 3-Phase Monitor

READ ALL INSTRUCTIONS BEFORE INSTALLING, OPERATING OR SERVICING THIS DEVICE.
KEEP THIS DATA SHEET FOR FUTURE REFERENCE.

GENERAL SAFETY

POTENTIALLY HAZARDOUS VOLTAGES ARE PRESENT AT THE TERMINALS OF THE MODEL 258.
ALL ELECTRICAL POWER SHOULD BE REMOVED WHEN CONNECTING OR DISCONNECTING WIRING.
THIS DEVICE SHOULD BE INSTALLED AND SERVICED BY QUALIFIED PERSONNEL.

Installation Instructions

WARNING

IN APPLICATIONS WHERE VOLTAGES IN EXCESS OF 300 VAC ARE TO BE MONITORED, BE CERTAIN TO USE THE TIME MARK MODEL 51X120 8-PIN SOCKET, OR AN EQUIVALENT UL APPROVED 600 VAC RATED SOCKET.

INSTALLATION

Mount the 8-pin socket in a suitable enclosure. A NEMA-1 rated enclosure, designed for socket-mounted relays is available from Time Mark Corporation.

Connect 3-phase power to terminals 3, 4, and 5 on the socket. Phase rotation should be verified using a Time Mark Model 108A or 108B Phase Sequence Detector.

Connect the load control wiring to the appropriate terminals on the socket:

For motor control applications; use terminals 1 and 8.

For phase loss alarm applications; use terminals 1 and 2.

Insert the Model 258 into the socket and apply power. If the contact does not transfer (*green light ON*), check that all phases are present, and of the correct voltage. If power is correct, rotate the level adjustment counter-clockwise.

If the contact still does not transfer, remove power and reverse any two of the three phase wires at the socket (*phase rotation is reversed*). Re-apply power. The contact should transfer to provide a signal path between pins 1 and 8.

NOTE: When installing the Model 258 monitor in areas of high humidity or contamination, it is recommended that the base area and all exposed metal parts of the socket be coated liberally with a good quality silicon grease, such as Dow Corning DC-4 or DC-4X. Insert the unit into the socket and wipe off excess grease around the base. This will prevent the entrance of moisture and other contaminants into the base and socket areas.

ADJUSTMENT SETTINGS

The following procedure will allow the Model 258 to be adjusted to achieve a trip point just below the nominal phase-to-phase voltage, where the unit is applied.

Rotate the adjustment control fully clockwise, or until the red (TRIP) indicator illuminates.

Slowly rotate the adjustment control in a counter-clockwise direction, just until the green (NORM) indicator illuminates.

At this point, the Model 258 is the most sensitive to irregular power line conditions. If nuisance tripping occurs, turn the control slightly farther counter-clockwise.

A more accurate setting will require the use of a 3-phase variac to lower the voltage to an exact measurable setting. Time Mark also offers a factory set version of all models and voltage ranges, for only a small additional charge.

TROUBLESHOOTING

Should the Model 258 Monitor fail to operate properly, check that all three voltages are present, and are of the correct voltage level and phase rotation (a Model 108A or 108B Phase Sequence Detector should be used to verify phase rotation). Check all fuses and verify that all wiring connections are correct. If problems persist, contact your local Time Mark Distributor, or the factory for assistance (*Monday-Friday, 8 a.m. to 5 p.m. CST*).

MANUAL RESET VERSIONS

IF YOU DO NOT WISH TO USE A NORMALLY CLOSED EXTERNAL RESET SWITCH ON THE MANUAL RESET VERSION, YOU MUST JUMPER PINS 6 AND 7. Refer to the Manual Reset 8-pin diagram.

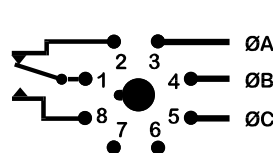

Automatic Reset

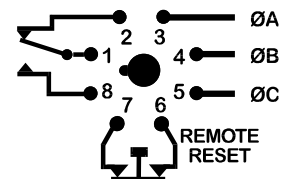

Manual Reset

WARRANTY

The **Model 258 3-Phase Monitor** is warranted to be free from defects in materials and workmanship, and is covered by our exclusive **5-year Unconditional Warranty**. If this device fails to operate, for any reason, we will repair or replace it free, for five years from the date of purchase. Contact the Time Mark Sales department for further details.

Telephone: Main - (918) 438-1220

Sales - (800) 862-2875

Fax: (918) 437-7584

E-mail: sales@time-mark.com

Internet: http://www.time-mark.com



TIME MARK
CORPORATION

11440 East Pine Street
Tulsa, Oklahoma 74116

Doc No. 87A123 07/2011
© 2011 TIME MARK CORPORATION

TIME MARK is a division of  AEMT, Inc.

MODEL 2581

3-Phase Monitor

- Detects Phase Loss, Low Voltage and Phase Reversal
- Encapsulated Circuitry
- LED Status Indicator
- 1/4" Quick-connect Terminals



DESCRIPTION

The **Model 2581 3-Phase Monitor** is designed to continuously monitor 3-phase power lines for phase loss, low voltage and phase reversal. The Model 2581 Monitor will detect phase loss on a loaded motor even when regenerated voltage is present.

This device consists of a solid-state voltage and phase-angle sensing circuit, driving an electromechanical relay. When correct voltage and phase rotation are applied, the internal relay will energize. A fault condition will de-energize the relay. When the fault is corrected, the monitor will automatically reset.

The Model 2581 3-Phase Monitor does not require a neutral connection and can be used with Wye or Delta configured systems. Low voltage trip point is factory set at 10% below nominal. An LED indicator is provided for system troubleshooting.

SPECIFICATIONS

Model	2581-208	2581-220	2581-240	2581-480
Nominal Voltage (phase to phase)	208VAC	220VAC	240VAC	480VAC
Trip Point	189VAC	200VAC	218VAC	436VAC
Trip Point Tolerance	± 2%			
Frequency	60 Hz			
Power Consumption	1.5W	1.65W	1.86W	4.5W
Transient Protection	2500 VRMS for 10msec			
Repeat Accuracy	±0.1% (fixed conditions)			
Response Time	50 msec (set or reset)			
Dead Band	Approx. 4%			
Contact Rating	SPDT 10 amps at 240VAC resistive			
Expected Relay Life	Mech: 10 million operations Elec: 100,000 operations at rated load			
Operating Temperature	- 40° to +131° F			
Humidity Tolerance	97% w/o condensation			
Enclosure Material	ABS plastic			
Agency Approvals	Recognized to U.S. and Canadian requirements under the Component Recognition Program of Underwriters Laboratories, Inc.			

TYPICAL APPLICATION

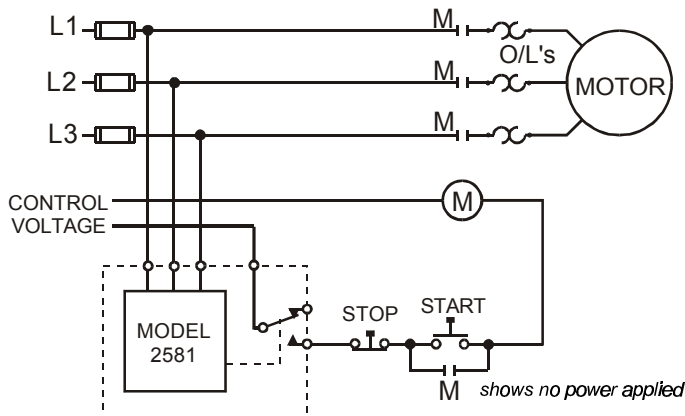

DIMENSIONS - 208 to 240V versions

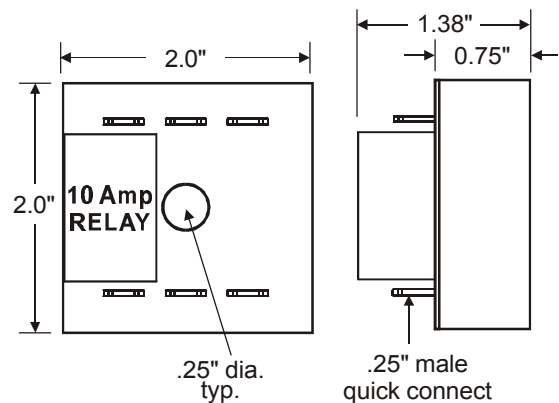

Telephone: Main - (918) 438-1220
Sales - (800) 862-2875
Fax: (918) 437-7584

E-mail: sales@time-mark.com
Internet: http://www.time-mark.com



11440 East Pine Street
Tulsa, Oklahoma 74116
Doc No. 87A459 12/00
© 2000 TIME MARK CORPORATION

TIME MARK is a division of AEMT, Inc.

MODEL 2581 3-Phase Monitor

READ ALL INSTRUCTIONS BEFORE INSTALLING, OPERATING OR SERVICING THIS DEVICE.
KEEP THIS DATA SHEET FOR FUTURE REFERENCE.

GENERAL SAFETY

POTENTIALLY HAZARDOUS VOLTAGES ARE PRESENT AT THE TERMINALS OF THE MODEL 2581.
ALL ELECTRICAL POWER SHOULD BE REMOVED WHEN CONNECTING OR DISCONNECTING WIRING.
THIS DEVICE SHOULD BE INSTALLED AND SERVICED BY QUALIFIED PERSONNEL.

Installation Instructions

INSTALLATION

Mount the **Model 2581 3-Phase Monitor** on a flat surface, in a well ventilated area. It should be fastened in position with a 1/4" bolt, washer and nut (*not included*), through the center mounting hole on the unit.

Use 1/4" quick disconnect lugs, or an equivalent, to connect the 3-phase power to the terminals marked **A**, **B** and **C**.

Connect the control circuit to the terminals with the contact markings. A standard wiring diagram is shown in the TYPICAL APPLICATION drawing.

If the contact does not transfer (LED indicator-On), check that all phases are present and of the correct voltage.

If the contact still does not transfer, remove power and reverse any two of the three phase wires (*phase rotation is reversed*). Re-apply power. The contact should transfer to provide a signal path between terminals.

DIMENSIONS - 480V version

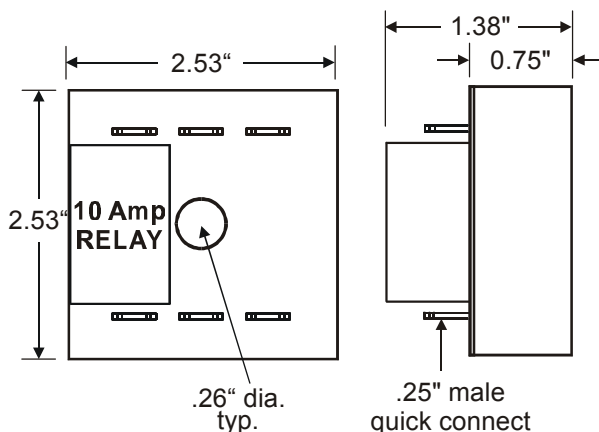

TROUBLESHOOTING

Should the Model 2581 Monitor fail to operate properly, check that all three voltages are present, and are of the correct voltage level and phase rotation (a Time Mark Model 108A or 108B Phase Sequence Detector should be used to verify phase rotation). Check all fuses and verify that all wiring connections are correct. If problems persist, contact your local Time Mark Distributor or the factory for assistance (*Monday-Friday, 8 a.m. to 5 p.m. CST*).

PIN DIAGRAM

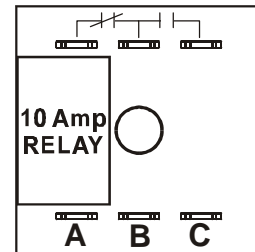

WARRANTY

The **Model 2581 3-Phase Monitor** is covered by Time Mark Corporation's exclusive **5-Year Unconditional Warranty**. Should this device fail, for any reason, within five years from the date of purchase, we will repair or replace it free. Contact the Time Mark Sales department, Monday through Friday; 8 a.m. to 5 p.m., CST, for further details.

Telephone: Main - (918) 438-1220
Sales - (800) 862-2875
Fax: (918) 437-7584

E-mail: sales@time-mark.com
Internet: http://www.time-mark.com



11440 East Pine Street
Tulsa, Oklahoma 74116
Doc No. 87A459 12/00
© 2000 TIME MARK CORPORATION

TIME MARK is a division of  AEMT, Inc.

MODEL 259

3-Phase Monitor

- DPDT 600VAC Output Contacts
- Adjustable Trip & Restart Delays
- Adjustable Voltage Level
- 5 Year Unconditional Warranty

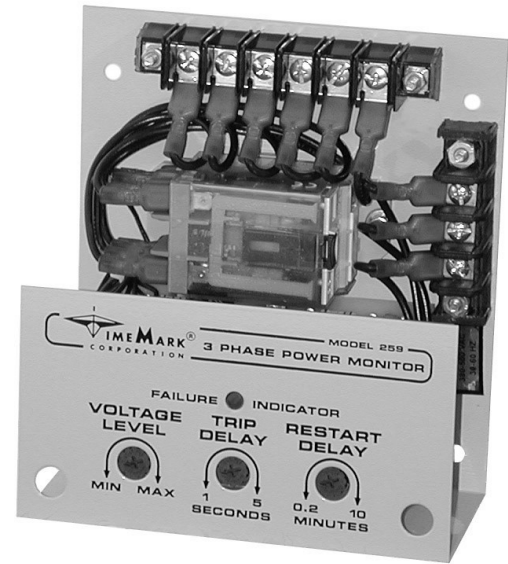

DESCRIPTION

The **Model 259 3-Phase Monitor** is designed to protect individual 3-phase equipment and motors, when used alone or in conjunction with shunt trip breakers. When correct voltage and phase rotation are applied an internal DPDT relay energizes.

A fault condition (phase loss, phase reversal, or low voltage) drops out the relay and lights the LED failure indicator. The Model 259 will detect a phase loss condition even when regenerative voltage is present.

The Model 259 may be used with Wye or Delta systems and requires no neutral connection. Standard operating ranges are available from 120 to 575 VAC, 60 Hz and 380 VAC, 50 Hz.

SPECIFICATIONS

Model	A259	B259	C259	D259	EX259
Nominal AC Voltage (phase to phase)	120VAC	208/240 VAC	480VAC	575VAC	380VAC
Adjust Range (VAC)	85-125	160-260	380-500	450-600	300-400
Frequency	60 Hz				50 Hz
Power Consumption	2.1 W	3.3 W	4.2 W	6.9 W	4.2 W
Transient Protection	2500V for 10 msec				
Repeat Accuracy	± 0.1 % (fixed conditions)				
Response Time	Adjustable 1 to 5 seconds				
Reset Time	Adjustable 0.2 to 10 minutes				
Reset Type	Automatic				
Dead Band	Approximately 2%				
Output Contacts	DPDT	3A at 480/600 VAC 10A at 240VAC	80% PF 80% PF resistive		
Expected Relay Life	Mech: 10 million operations Elec: 100,000 operations at rated load				
Operating Temp	- 20° to +131° F				
Humidity Tolerance	0-97% w/o condensation				
Enclosure Material	20 gauge steel				
Mounting	Surface				
Weight	17 oz.				

DIMENSIONS

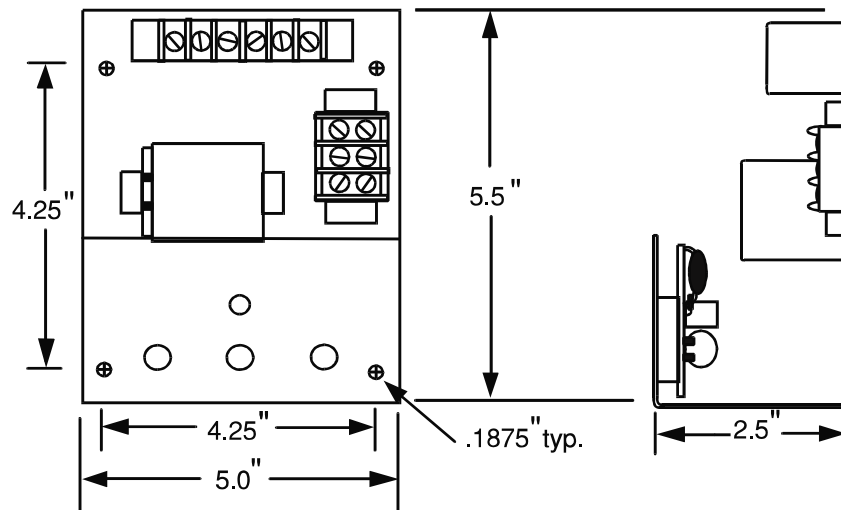

Telephone: Main - (918) 438-1220
Sales - (800) 862-2875
Fax: (918) 437-7584

E-mail: sales@time-mark.com
Internet: http://www.time-mark.com



11440 East Pine Street
Tulsa, Oklahoma 74116

Doc No. 87A116 07/2011
© 2011 TIME MARK CORPORATION

TIME MARK is a division of  AEMT, Inc.

MODEL 259 3-Phase Monitor

READ ALL INSTRUCTIONS BEFORE INSTALLING, OPERATING OR SERVICING THIS DEVICE.
KEEP THIS DATA SHEET FOR FUTURE REFERENCE.

GENERAL SAFETY

POTENTIALLY HAZARDOUS VOLTAGES ARE PRESENT AT THE TERMINALS OF THE MODEL 259.
ALL ELECTRICAL POWER SHOULD BE REMOVED WHEN CONNECTING OR DISCONNECTING WIRING.
THIS DEVICE SHOULD BE INSTALLED AND SERVICED BY QUALIFIED PERSONNEL.

Installation Instructions

INSTALLATION

Connect the 3-phase wiring to the terminals marked **L1, L2, L3**.

Connect the control wiring to the terminals with the contact markings (refer to the diagram on the unit). The markings shown on the unit are the failed condition of the contacts.

Apply power. If the contacts do not transfer (FAILURE INDICATOR=Off), check that all three phases are present and of the correct voltage. If all phases are correct, rotate the VOLTAGE LEVEL adjustment counter-clockwise to the MIN position.

If the contacts still do not transfer, remove power from the unit. Reverse two of the three input wires and re-apply power. The contacts should transfer to the normal condition (normally-open contacts closed, FAILURE INDICATOR=Off).

Note: Upon initial power up with proper voltage and phase sequence it will take about 12 seconds before the trip led will go out and the contacts will transfer to the normal state. When making voltage level adjustments after the unit is tripped the above will apply.

ADJUSTMENT

Note: During adjustment you may want to install a jumper across the control contacts to prevent cycling the load on and off.

Set the TRIP DELAY to 1 second. Rotate the VOLTAGE LEVEL adjustment slowly clockwise, until the contacts transfer to the failed condition (FAILURE INDICATOR=On). Slowly turn the adjustment counterclockwise until the contacts reset to the normal condition (FAILURE INDICATOR=Off).

Remove the jumper, if installed.

This setting will be correct for most applications. The trip delay will prevent most nuisance tripping; however, if nuisance tripping does occur, turn the VOLTAGE LEVEL slightly farther counter-clockwise.

In making adjustments to eliminate nuisance tripping, the VOLTAGE LEVEL adjustment should be rotated in very small increments until the true nuisance trips are eliminated. Adjust the TRIP DELAY setting, and RE-START DELAY as required for the application.

TYPICAL APPLICATION

Shunt Trip Breaker Operation

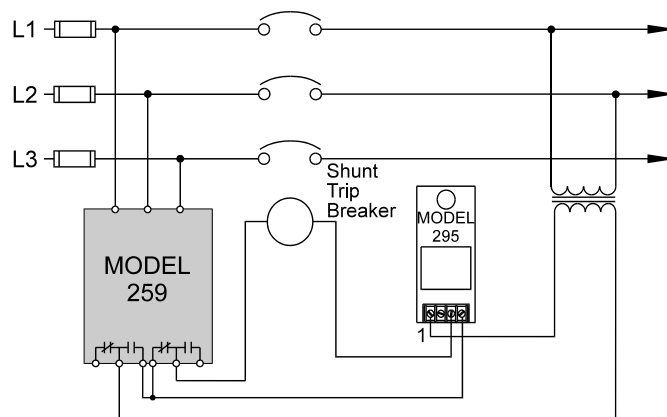

TYPICAL APPLICATION

Individual Motor Protection

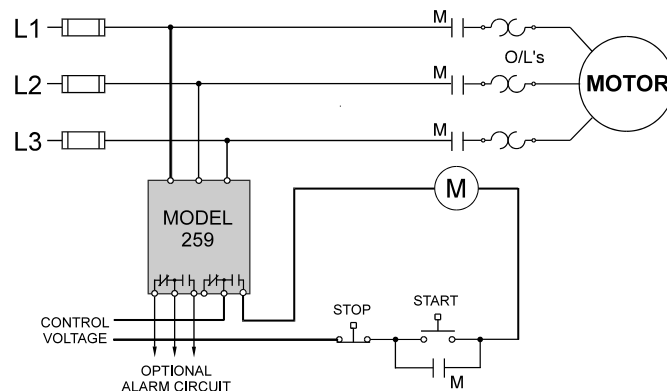

WARRANTY

The **Model 259 3-Phase Monitor** is covered by Time Mark Corporation's exclusive **5-Year Unconditional Warranty**. Should this device fail, for any reason, within five years from the date of purchase, we will repair or replace it free. Contact the Time Mark Sales department, Monday through Friday; 8 a.m. to 5 p.m., CST, for further details.

Telephone: Main - (918) 438-1220

Sales - (800) 862-2875

Fax: (918) 437-7584

E-mail: sales@time-mark.com

Internet: http://www.time-mark.com



TIME MARK
CORPORATION

11440 East Pine Street
Tulsa, Oklahoma 74116

Doc No. 87A116 07/2011
© 2011 TIME MARK CORPORATION

TIME MARK is a division of  **AEMT, Inc.**

MODEL 2594

3-Phase Monitor

- DPDT 600VAC Output Contacts
- Adjustable Failure Level
- Automatic Reset
- 5 Year Unconditional Warranty

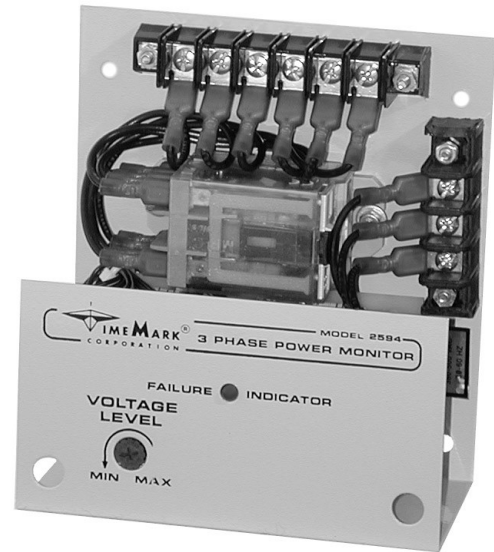

DESCRIPTION

The **Model 2594 3-Phase Monitor** is designed for use with applications which require high control voltage (up to 600VAC). The Model 2594 protects 3-phase equipment and motors from phase loss, phase reversal and low voltage. When the correct voltage and phase rotation are applied, an internal DPDT relay energizes.

A fault condition drops out the relay and the FAILURE INDICATOR LED illuminates. When the existing fault is corrected the unit will automatically reset. The Model 2594 can detect a phase loss condition even when regenerative voltage is present. It may be used with WYE or Delta systems; no neutral connection required.

Standard operating ranges are available from 120 to 575VAC, 60 Hz and 380VAC, 50 Hz.

SPECIFICATIONS

Model	A2594	B2594	C2594	D2594	EX2594
Nominal AC Voltage (phase to phase)	120VAC	208/240VAC	480VAC	575VAC	380VAC
Adjustment Range	85-125	160-260	380-500	450-600	300-400
Frequency	60 Hz				50 Hz
Power Consumption	2.1W	3.3W	4.2W	6.9W	4.2W
Transient Protection	2500V for 10 msec				
Repeat Accuracy	± 0.1% (fixed conditions)				
Response Time	0.05 seconds (fixed)				
Reset Time	0.05 seconds (fixed)				
Reset Type	Automatic				
Output Contacts	DPDT	3A at 480/600 VAC 80% PF 10A at 240 VAC 80% PF resistive			
Expected Relay Life	Mech: 10 million operations Elec: 100,000 at rated load				
Operating Temp	- 20° to +131° F				
Humidity Tolerance	0-97% w/o condensation				
Enclosure Material	20 gauge steel				
Mounting	Surface				
Weight	17 oz.				

DIMENSIONS

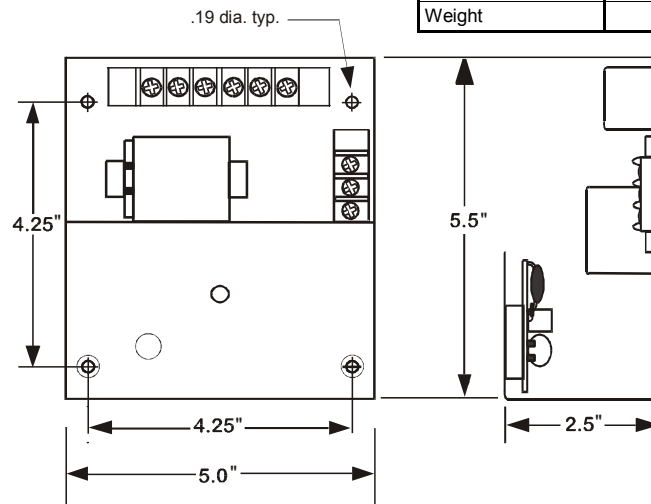

Telephone: Main - (918) 438-1220
Sales - (800) 862-2875
Fax: (918) 437-7584

E-mail: sales@time-mark.com
Internet: http://www.time-mark.com



11440 East Pine Street
Tulsa, Oklahoma 74116

Doc No. 87A394 07/2011
© 2011 TIME MARK CORPORATION

TIME MARK is a division of  AEMT, Inc.

MODEL 2594 3-Phase Monitor

READ ALL INSTRUCTIONS BEFORE INSTALLING, OPERATING OR SERVICING THIS DEVICE.
KEEP THIS DATA SHEET FOR FUTURE REFERENCE.

GENERAL SAFETY

POTENTIALLY HAZARDOUS VOLTAGES ARE PRESENT AT THE TERMINALS OF THE MODEL 2594.
ALL ELECTRICAL POWER SHOULD BE REMOVED WHEN CONNECTING OR DISCONNECTING WIRING.
THIS DEVICE SHOULD BE INSTALLED AND SERVICED BY QUALIFIED PERSONNEL.

Installation Instructions

INSTALLATION

Connect the 3-phase wiring to the terminals marked L1, L2, L3.

Connect the control wiring to the terminals with the contact markings (refer to the diagram on the unit). The markings shown on the unit are the failed condition of the contacts.

Apply power.

If the contacts do not transfer (FAILURE INDICATOR-On), check that all three phases are present and of the correct voltage.

If all phases are correct, rotate the VOLTAGE LEVEL adjustment counter-clockwise to the MIN position. If the contacts still do not transfer, remove power from the unit.

Reverse two of the three input wires and re-apply power. The contacts should transfer to the normal condition (normally-open contacts closed, FAILURE INDICATOR-Off).

ADJUSTMENT

Note: During adjustment you may wish to install a jumper across the control contacts to prevent cycling the load on and off.

Rotate the VOLTAGE LEVEL adjustment slowly clockwise until the contacts transfer to the failed condition (FAILURE INDICATOR-On). Slowly turn the adjustment counter-clockwise until the contacts reset to the normal condition (FAILURE INDICATOR-Off).

Remove the jumper, if installed.

This setting will be correct for most applications. If nuisance tripping occurs, turn the VOLTAGE LEVEL slightly farther counter-clockwise.

Any adjustments to the VOLTAGE LEVEL, to eliminate nuisance tripping, should be made in very small increments, until the true nuisance trips are eliminated.

TYPICAL APPLICATION

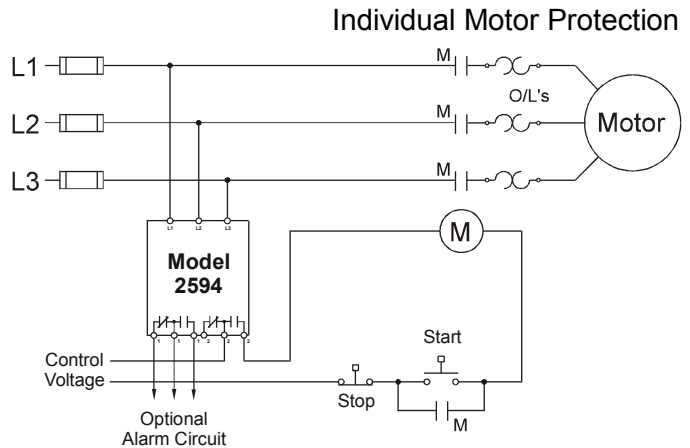

TYPICAL APPLICATION

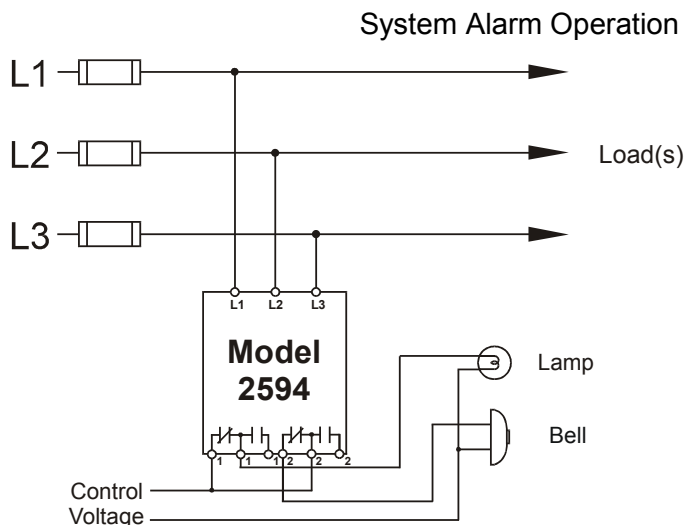

WARRANTY

The **Model 2594 Monitor** is covered by Time Mark Corporation's exclusive **5-Year Unconditional Warranty**. Should this device fail, for any reason, within five years from the date of purchase, we will repair or replace it free. Contact the Time Mark Sales department, Monday through Friday; 8 a.m. to 5 p.m., CST, for further details.

Telephone: Main - (918) 438-1220

Sales - (800) 862-2875

Fax: (918) 437-7584

E-mail: sales@time-mark.com

Internet: http://www.time-mark.com



TIME MARK
CORPORATION

11440 East Pine Street
Tulsa, Oklahoma 74116

Doc No. 87A394 07/2011
© 2011 TIME MARK CORPORATION

TIME MARK is a division of  AEMT, Inc.

MODEL 263

3-Phase Monitor

- Detects Phase Loss or Reversal and Low Voltage
- 400Hz and Gold Contact Options
- Automatic or Manual Reset
- UL Recognized and CSA Certified



DESCRIPTION

The **Model 263** continuously monitors 3-phase power systems for phase loss, low voltage and phase reversal. The monitor consists of a solid-state sensing circuit, driving an electromechanical relay.

Applying correct voltage and phase rotation energizes the relay. When properly adjusted, a fault condition will cause the relay to de-energize, even when regenerated voltage is present.

When the fault is corrected, the Model 263 automatically resets. A manual reset version is also available. The SG Model has silver with gold flash contacts for low current applications.

The Model 263 does not require a neutral connection, and can be used on Wye or Delta systems. Each of the five different voltage ranges is adjustable to allow the monitor to be set for existing conditions. NORMAL and TRIP LED indicators are provided to aid in adjustment and system troubleshooting.

SPECIFICATIONS

AUTO Reset	A263	B263	C263	D263	EX263
MANUAL Reset	A263M	B263M	C263M	D263M	EX263M
GOLD-AUTO Reset	A263SG	B263SG	C263SG	D263SG	EX263SG
GOLD-MAN Reset	A263SGM	B263SGM	C263SGM	D263SGM	EX263SGM
Nominal AC voltage (phase to phase)	120 VAC	208/240VAC	480 VAC	575 VAC	380 VAC
Adjustment Range	85-120V	160-240V	380-480V	450-575V	300-400V
Frequency	60 Hz	60 Hz	60 Hz	60 Hz	50 Hz
Power Consumption	0.75W	1.5W	4.5W	7.5W	4.5W
Transient Protection	2500 VRMS for 10msec				
Repeat Accuracy	± 0.1% of setpoint (fixed conditions)				
Response Time	50 msec				
Dead Band	Approximately 2%				
Output Contacts	All SG models: SPDT silver w/gold flash 5 amps at 240VAC resistive All other models: SPDT 10 amps at 240 VAC resistive				
Expected Relay Life	Mech: 10 million operations Elec: 100,000 operations at rated load				
Operating Temp	- 20° to +131° F				
Humidity Tolerance	0 - 97% w/o condensation				
Enclosure Material	ABS plastic				
Mounting	surface				
Weight	9.5 oz				
Agency Approvals	ALL VERSIONS - UL Recognized and CSA Certified				

DIMENSIONS

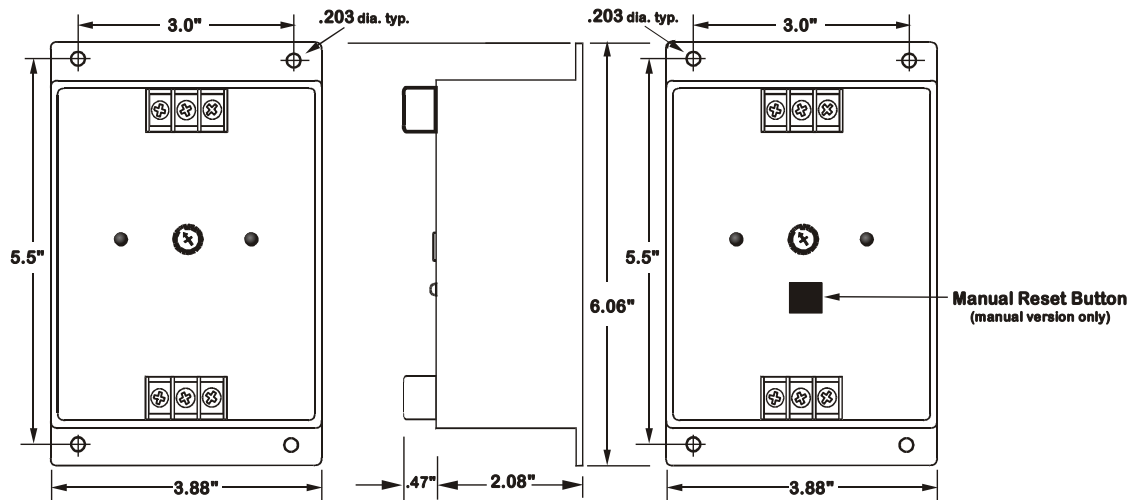

Telephone: Main - (918) 438-1220
Sales - (800) 862-2875
Fax: (918) 437-7584

E-mail: sales@time-mark.com
Internet: http://www.time-mark.com



TIME MARK
CORPORATION

11440 East Pine Street
Tulsa, Oklahoma 74116

Doc No. 87A124 07/2011
© 2011 TIME MARK CORPORATION

TIME MARK is a division of  AEMT, Inc.

MODEL 263 3-Phase Monitor

READ ALL INSTRUCTIONS BEFORE INSTALLING, OPERATING OR SERVICING THIS DEVICE.
KEEP THIS DATA SHEET FOR FUTURE REFERENCE.

GENERAL SAFETY

POTENTIALLY HAZARDOUS VOLTAGES ARE PRESENT AT THE TERMINALS OF THE MODEL 263.
ALL ELECTRICAL POWER SHOULD BE REMOVED WHEN CONNECTING OR DISCONNECTING WIRING.
THIS DEVICE SHOULD BE INSTALLED AND SERVICED BY QUALIFIED PERSONNEL.

Installation Instructions

INSTALLATION

Connect the 3-phase wires to the terminals marked **A**, **B** and **C**.

The control wiring will be connected to the opposite end of the unit, to the terminals with the contact markings. Markings on the unit are the failed condition of the contacts.

AUTOMATIC RESET VERSIONS:

Apply power. If the contacts do not transfer (TRIP LED-Off), check that all three phases are present and of the correct voltage.

If all phases are correct, rotate the VOLTS adjustment potentiometer counter-clockwise, to the low position.

If the contacts still do not transfer, remove power from the unit. Reverse any two of the three input wires and re-apply power. The contacts should transfer to the energized condition; N.O. contact-closed, NORMAL LED-On.

MANUAL RESET VERSIONS:

Apply power and press the RESET button. If the contacts do not transfer (TRIP LED-Off), check that all three phases are present and of the correct voltage.

If all phases are correct, rotate the VOLTS adjustment potentiometer counter-clockwise, to the low position and press the RESET button.

If the contacts still do not transfer, remove power from the unit. Reverse any two of the three input wires and re-apply power. Press the RESET button. The contacts should then transfer to the energized condition; N.O. contact-closed, NORMAL LED-On.

TYPICAL APPLICATION

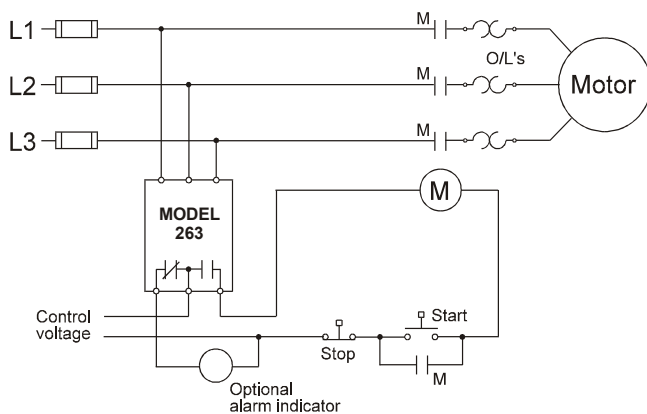

ADJUSTMENT SETTINGS

NOTE: During adjustment, you may wish to install a jumper across the control contacts, to prevent cycling the load on and off.

AUTOMATIC RESET VERSIONS:

Rotate the VOLTS adjustment slowly clockwise, until the contacts transfer to the failed condition (TRIP LED-On).

Slowly turn the adjustment back counter-clockwise, until the contacts reset to the normal condition (TRIP LED-Off).

Remove the jumper, if installed. This setting will be correct for most applications.

If nuisance tripping occurs, turn the adjustment slightly farther counter-clockwise. In adjustments to eliminate nuisance tripping, the VOLTS adjustment should be rotated in very small increments, until the true nuisance trips are eliminated.

MANUAL RESET VERSIONS:

During adjustment, you will need to press and hold the RESET button.

Rotate the VOLTS adjustment slowly clockwise, until the contacts transfer to the failed condition (TRIP LED-On). A slight buzz in the contacts may occur when the relay is at the transfer point to the failed condition. This is normal and will not occur in operation.

Slowly turn the VOLTS adjustment back counter-clockwise, until the contacts reset to the normal condition (NORMAL LED -On).

Release the RESET button, and remove the jumper, if installed. This setting will be correct for most applications.

If nuisance tripping occurs, turn the adjustment slightly farther counter-clockwise. In adjustments to eliminate nuisance tripping, the VOLTS adjustment should be rotated in very small increments, until the true nuisance trips are eliminated.

WARRANTY

The **Model 263 3-Phase Monitor** is covered by Time Mark Corporation's exclusive **5-Year Unconditional Warranty**. Should this device fail, for any reason, within five years from the date of purchase, we will repair or replace it free. Contact the Time Mark Sales department, Monday through Friday; 8 a.m. to 5 p.m., CST, for further details.

Telephone: Main - (918) 438-1220

Sales - (800) 862-2875

Fax: (918) 437-7584

E-mail: sales@time-mark.com

Internet: http://www.time-mark.com



TIME MARK
CORPORATION

11440 East Pine Street
Tulsa, Oklahoma 74116

Doc No. 87A124 07/2011
© 2011 TIME MARK CORPORATION

TIME MARK is a division of  **AEMT, Inc.**

MODEL 2638

3-Phase Monitor

with Line Voltage & Phase Sequence Indicator

- Detects Phase Loss, Phase Reversal and Low Voltage
- LED Status Indicators
- Automatic Reset
- 5 Year Unconditional Warranty



DESCRIPTION

The Model 2638 3-Phase Monitor combines a 3-phase monitor with a line voltage and phase sequence indicator. Like other Time Mark monitors, the Model 2638 senses phase loss, phase reversal and low voltage.

When power and phasing are correct, the internal relay energizes. Status indicators will show that all phases are present, and the direction of phase rotation.

When a fault occurs, the monitor trips its relay and indicates which phase is lost, or, if a reversal is present. This allows you to automatically protect your equipment by correcting for the appropriate fault condition. The Model 2638 will automatically reset when correct power is restored.

One 50 Hz version and two 60 Hz versions are available from stock.

SPECIFICATIONS

Model	B2638	C2638	EX2638
Nominal Voltage	208/240 VAC	480 VAC	380 VAC
Frequency	60 Hz		50 Hz
Adjustment Range	160-240	380-480	300-400
Power Consumption	3.7W	6.7W	6.5W
Transient Protection	2500V for 10 msec		
Repeat Accuracy	±0.1% (fixed conditions)		
Response Time	0.05 seconds		
Reset Time	0.05 seconds		
Reset Type	Automatic		
Dead Band	Approximately 2%		
Output Contacts	SPDT 10A at 240 VAC resistive		
Expected Relay Life	Mech: 10 million operations Elec: 100,000 operations at rated load		
Operating Temperature	-20° to +131° F		
Humidity Tolerance	0-97% w/o condensation		
Enclosure Material	ABS plastic		
Mounting	Surface		
Weight	12 oz.		

DIMENSIONS

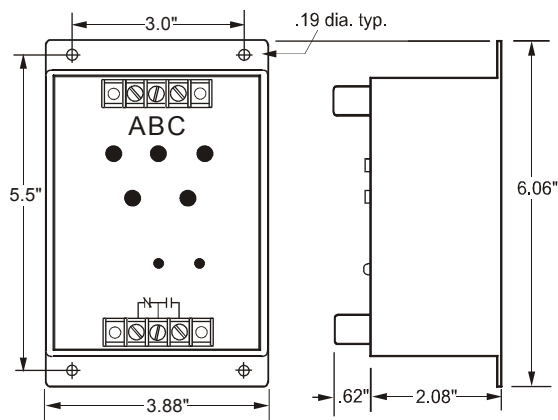

Telephone: Main - (918) 438-1220
Sales - (800) 862-2875
Fax: (918) 437-7584

E-mail: sales@time-mark.com
Internet: http://www.time-mark.com



11440 East Pine Street
Tulsa, Oklahoma 74116

Doc No. 87A371 07/2011
© 2011 TIME MARK CORPORATION

TIME MARK is a division of  AEMT, Inc.

MODEL 2638 3-Phase Monitor

READ ALL INSTRUCTIONS BEFORE INSTALLING, OPERATING OR SERVICING THIS DEVICE.
KEEP THIS DATA SHEET FOR FUTURE REFERENCE.

GENERAL SAFETY

POTENTIALLY HAZARDOUS VOLTAGES ARE PRESENT AT THE TERMINALS OF THE MODEL 2638.
ALL ELECTRICAL POWER SHOULD BE REMOVED WHEN CONNECTING OR DISCONNECTING WIRING.
THIS DEVICE SHOULD BE INSTALLED AND SERVICED BY QUALIFIED PERSONNEL.

Installation Instructions

INSTALLATION

Mount the monitor in a suitable enclosure.

Connect 3-phase power to the terminals marked A, B and C.

For motor control applications, connect the load control wiring to the normally open (NO) relay contacts.

For phase loss alarm applications, connect wiring to the normally closed (NC) relay contacts.

Apply power. If the contacts do not transfer (TRIPPED indicator ON), check that the three voltage indicators are lit and that the ABC indicator is lit.

If one or more of the voltage indicators are off, not all phases are present or of the correct voltage level.

If the CBA indicator is lit, remove power and reverse two of the three phase wires (phase rotation is reversed).

Re-apply power. If the contacts still do not transfer, rotate the TRIPPED level adjustment fully counter-clockwise. The contacts should transfer, the TRIPPED indicator should be off, the ABC indicator should be lit, and all three voltage indicators should be lit.

ADJUSTMENT

Rotate the TRIPPED level adjustment clockwise until the relay contact transfers (TRIPPED indicator ON). Slowly turn the adjustment counter-clockwise, until the contacts resets.

This adjustment method sets the trip point roughly 5-10% below the nominal voltage, and will be correct for most motor applications. Should nuisance tripping occur, turn the adjustment slightly farther counter-clockwise.

A more accurate adjustment method requires a 3-phase variac, allowing the voltage to be lowered to a specific voltage level. The 2638 can then be set to trip at this precise voltage.

If desired, the trip point can be factory pre-set for a nominal fee. Contact the factory for more information.

TYPICAL APPLICATION

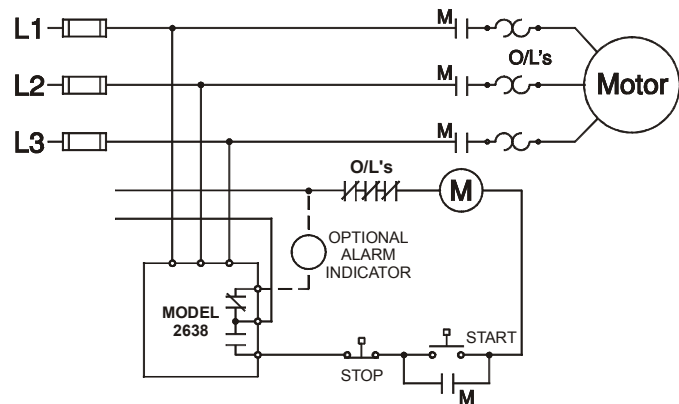

Shown De-Energized

TROUBLESHOOTING

Should the monitor fail to operate properly, check that all three phases are present and of the correct voltage level. Check all fuses and verify that all wiring connections are correct. Should problems persist, contact the factory for assistance.

WARRANTY

The **Model 2638 3-Phase Monitor** is covered by Time Mark Corporation's exclusive **5-Year Unconditional Warranty**. Should this device fail, for any reason, within five years from the date of purchase, we will repair or replace it free. Contact the Time Mark Sales department, Monday through Friday, 8 a.m. to 5 p.m., CST, for further details.

Telephone: Main - (918) 438-1220
Sales - (800) 862-2875
Fax: (918) 437-7584

E-mail: sales@time-mark.com
Internet: http://www.time-mark.com



11440 East Pine Street
Tulsa, Oklahoma 74116
Doc No. 87A371 07/2011
© 2011 TIME MARK CORPORATION

TIME MARK is a division of  AEMT, Inc.

MODEL 264

3-Phase Monitor

- Detects Phase Loss, Low Voltage, Phase Reversal
- Adjustable Trip Delay
- Isolated Contacts
- 5 Year Unconditional Warranty

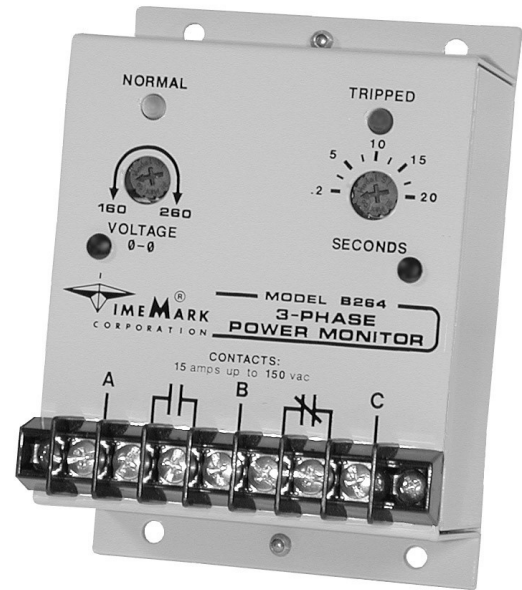

DESCRIPTION

The Model 264 3-Phase Monitor continuously monitors 3-phase Wye or Delta systems for abnormal conditions. The solid-state electronic sensing circuit drives two separate SPST relays, one normally open and the other normally closed. An adjustable trip delay reduces or eliminates nuisance tripping caused by momentary voltage fluctuations on motor start-up.

Standard versions are 120V, 208/240V, 480V and 575V at 60 Hz; and 380V or 415V at 50 Hz. Voltage ranges are sufficiently wide to allow for proper adjustment to existing conditions. Both TRIPPED and NORMAL indicators are provided to aid in trip point adjustments and system troubleshooting.

The Model 264 is not sensitive to line current and can be used with any size motor or compressor.

DIMENSIONS

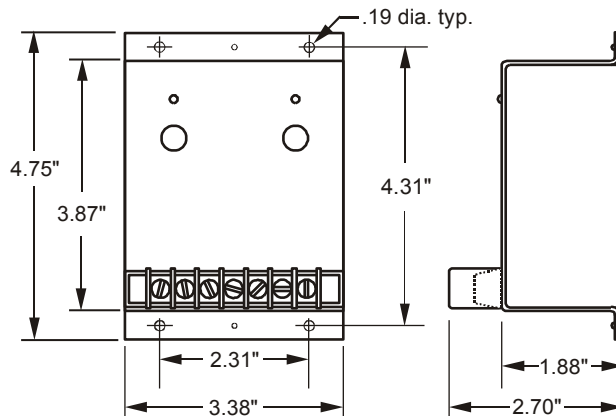

SPECIFICATIONS

Model	A264	B264	C264	D264	EX264-380	EX264-415
Nominal AC Voltage (phase to phase)	120 VAC	208/240 VAC	480VAC	575VAC	380VAC	415VAC
Adjustment Range	85-125V	160-260V	380-500V	450-600V	300-400V	340-460V
Frequency	60 Hz	60 Hz	60 Hz	60 Hz	50 Hz	50 Hz
Power Consumption (per phase)	0.25W	0.5W	1.5W	2.5W	1.5W	1.5W
Transient Protection	2500VAC for 10msec					
Repeat Accuracy	± 0.1% of set point (fixed conditions)					
Response Time	2 +/- 2 to 20 +10/-2 seconds					
Reset Time	0.15 seconds					
Reset Type	Automatic					
Dead Band	Approximately 8% of 125 VAC or 10 VAC					
Output Contacts	One (1) SPST N.O. One (1) SPST N.C.					
Contact Rating	10 amps at 240VAC resistive					
Expected Relay Life	Mech: 10 million operations Elec: 100,000 operations at rated load					
Operating Temp	- 20° to +130° F					
Humidity Tolerance	0 - 97% w/o condensation					
Enclosure Material	20 gauge steel					
Mounting	Surface					
Weight	10 oz.					

Telephone: Main - (918) 438-1220
Sales - (800) 862-2875
Fax: (918) 437-7584

E-mail: sales@time-mark.com
Internet: http://www.time-mark.com



TIME MARK
CORPORATION

11440 East Pine Street
Tulsa, Oklahoma 74116

Doc No. 87A127 07/2011
© 2011 TIME MARK CORPORATION

TIME MARK is a division of  AEMT, Inc.

MODEL 264 3-Phase Monitor

READ ALL INSTRUCTIONS BEFORE INSTALLING, OPERATING OR SERVICING THIS DEVICE.
KEEP THIS DATA SHEET FOR FUTURE REFERENCE.

GENERAL SAFETY

POTENTIALLY HAZARDOUS VOLTAGES ARE PRESENT AT THE TERMINALS OF THE MODEL 264.
ALL ELECTRICAL POWER SHOULD BE REMOVED WHEN CONNECTING OR DISCONNECTING WIRING.
THIS DEVICE SHOULD BE INSTALLED AND SERVICED BY QUALIFIED PERSONNEL.

Installation Instructions

WARNING

The Model 264 is not to be used in applications where voltages to be monitored or switched will exceed voltage specifications for the particular unit. See 'Adjustment Range' in the Specifications table on the reverse side of this data sheet.

INSTALLATION

Connect the 3-phase wires to the terminals marked **A**, **B** and **C**. Turn both controls fully counter-clockwise.

Connect the control wires to the terminals with the relay contact markings. **NOTE:** The contact markings on the unit are the **TRIPPED** condition of the contacts.

Apply power. If the contacts do not transfer when power is applied (NORMAL indicator on), check that all three phases are present, and of the correct voltage. If all phases are correct, rotate the **VOLTAGE** adjustment counter-clockwise, to the low position. If the contacts still do not transfer, remove power from the unit. Reverse any two of the three input wires, and re-apply power. The contacts should transfer to the normal condition (normally open contact closed, NORMAL indicator ON).

ADJUSTMENT

NOTE: During adjustment, you may want to install a jumper across the control contacts, to prevent cycling the load on and off.

Set the trip delay to .2 seconds.

Rotate the **VOLTAGE** adjustment slowly clockwise until the contacts transfer to the failed condition (TRIPPED indicator lit).

Slowly turn the **VOLTAGE** adjustment counter-clockwise, until the contacts reset to the normal condition (NORMAL indicator on).

If you installed a jumper across the control contacts to prevent load cycling, remove it now.

Set the **SECONDS** adjustment to the desired amount of trip delay. This trip delay will prevent most nuisance tripping; however, if nuisance tripping does occur, turn the **VOLTAGE** adjustment slightly farther, counter-clockwise.

In making adjustments to eliminate nuisance tripping, the **VOLTAGE** adjustment should be rotated in very small increments, until the true nuisance trips are eliminated.

TYPICAL APPLICATION

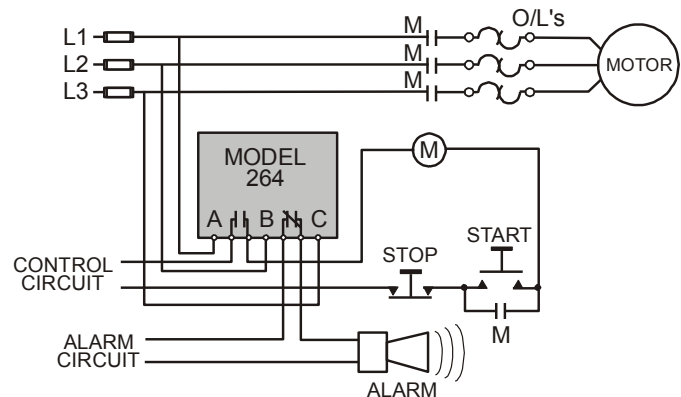

Shown De-Energized

WARRANTY

The **Model 264 3-Phase Monitor** is covered by Time Mark Corporation's exclusive **5-Year Unconditional Warranty**. Should this device fail, for any reason, within five years from the date of purchase, we will repair or replace it free. Contact the Time Mark Sales department, Monday through Friday; 8 a.m. to 5 p.m., CST, for further details.

Telephone: Main - (918) 438-1220

Sales - (800) 862-2875

Fax: (918) 437-7584

E-mail: sales@time-mark.com

Internet: http://www.time-mark.com



TIME MARK
CORPORATION

11440 East Pine Street
Tulsa, Oklahoma 74116

Doc No. 87A127 07/2011
© 2011 TIME MARK CORPORATION

TIME MARK is a division of  **AEMT, Inc.**

MODEL 2642

3-Phase Monitor



- Detects Phase Loss, Low Voltage and Phase Reversal
- Adjustable Trip Delay
- Automatic or Manual Reset
- DPDT Output Contacts

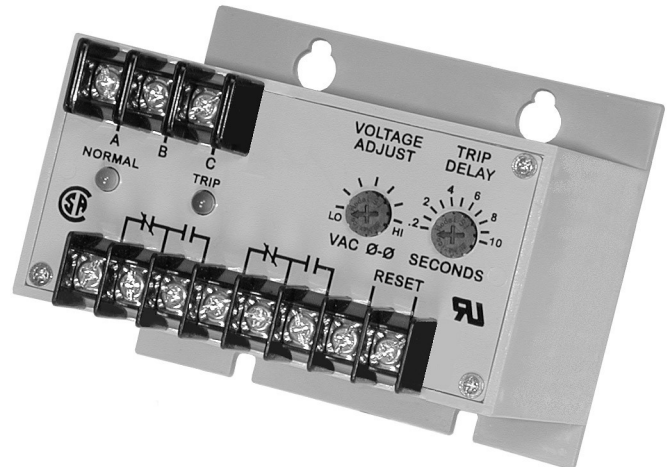

DESCRIPTION

The Model 2642 3-Phase Monitor protects electrical equipment by sensing phase loss, low voltage and reverse phase conditions. This device uses a combination of voltage and phase angle sensing, and will detect a phase loss even when regenerated voltages are present.

The Model 2642 is fail-safe; the output contacts will transfer when correct power is applied, and trip out on any fault condition or complete loss of power. Each of five voltage versions can be adjusted throughout a wide operating range. An adjustable trip delay timer prevents nuisance tripping caused by momentary voltage dips.

The DPDT output contacts allow the Model 2642 to be used in control circuits and alarm circuits. The automatic reset can be converted to a manual reset by adding a normally closed switch.

DIMENSIONS

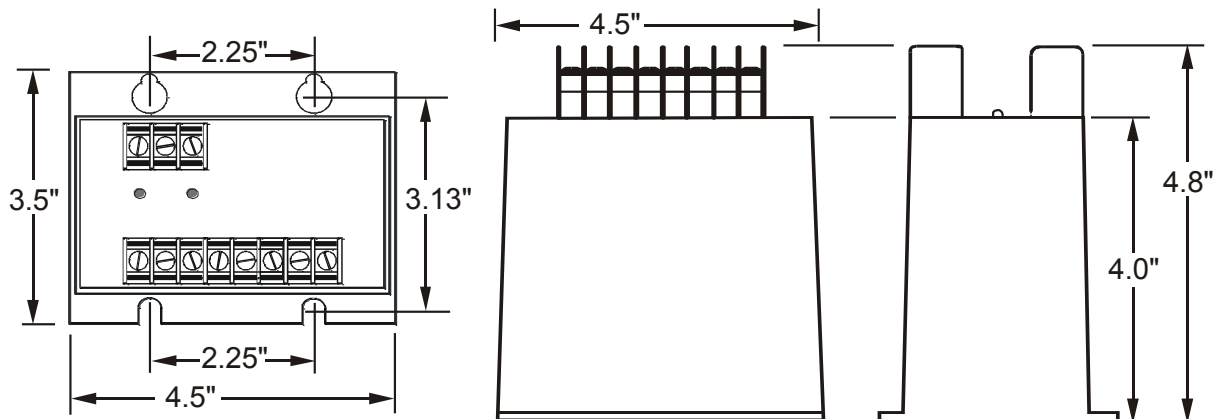

SPECIFICATIONS

MODEL	A2642	B2642	C2642	D2642	EX2642
Nominal AC Voltage (phase to phase)	120VAC	208/240VAC	480VAC	575VAC	380VAC
Adjustment Range	85-125V	160-260V	380-500V	450-600V	300-400V
Frequency	60Hz	60Hz	60Hz	60Hz	50 Hz
Power Consumption	0.25W	0.5W	1.5W	2.5W	1.5W
Transient Protection	2500 VRMS for 10msec				
Repeat Accuracy	± 0.5% of setpoint (fixed conditions)				
Response Time	Adjustable 0.2 to 10 seconds ±5%				
Reset Time	0.15 seconds				
Dead Band	Approximately 2%				
Output Contacts	DPDT 10 amps at 240VAC resistive				
Expected Relay Life	Mech: 10 million operations Elec: 100,000 operations at rated load				
Operating Temp	- 20° to +131° F				
Humidity Tolerance	0 - 97% w/o condensation				
Enclosure Material	ABS plastic				
Mounting	Surface				
Weight	12 oz.				
Agency Approvals	UL Recognized; CSA Certified				

Telephone: Main - (918) 438-1220
Sales - (800) 862-2875
Fax: (918) 437-7584

E-mail: sales@time-mark.com
Internet: http://www.time-mark.com



TIME MARK
CORPORATION

11440 East Pine Street
Tulsa, Oklahoma 74116

Doc No. 87A169 07/2011
© 2011 TIME MARK CORPORATION

TIME MARK is a division of  AEMT, Inc.

MODEL 2642 3-Phase Monitor

READ ALL INSTRUCTIONS BEFORE INSTALLING, OPERATING OR SERVICING THIS DEVICE.
KEEP THIS DATA SHEET FOR FUTURE REFERENCE.

GENERAL SAFETY

POTENTIALLY HAZARDOUS VOLTAGES ARE PRESENT AT THE TERMINALS OF THE MODEL 2642.
ALL ELECTRICAL POWER SHOULD BE REMOVED WHEN CONNECTING OR DISCONNECTING WIRING.
THIS DEVICE SHOULD BE INSTALLED AND SERVICED BY QUALIFIED PERSONNEL.

Installation Instructions

INSTALLATION

Turn both adjustment control potentiometers fully counter-clockwise.

Connect the 3-phase wires to the terminals marked **A**, **B** and **C**.

Connect the control wires to one set of the terminals with the relay contact markings. The contact markings on the unit are the failed or tripped condition of the contacts. The second set of output terminals can be used in an alarm circuit or in the control circuit of a second load. Refer to the TYPICAL APPLICATION drawing.

As provided, the Model 2642 has an Automatic Reset. If you prefer a Manual Reset, install a normally-closed push button across the terminals marked RESET. The Manual Reset leads should be kept as short as possible.

Apply power. If the contacts do not transfer when power is applied (TRIPPED indicator off; NORMAL indicator on), check that all three phases are present and of the correct voltage.

If all phases are correct, remove power from the unit, reverse any two of the **A**, **B** or **C** terminal wires (*phase rotation is reversed*), and re-apply power. The contacts should then transfer.

ADJUSTMENT

NOTE: When adjusting the Model 2642 you may wish to jumper the control circuit contacts (& disconnect the alarm contacts, if used) to prevent the unit from cycling the load.

Rotate the VOLTAGE ADJUST pot clock-wise until the unit trips (NORMAL indicator off, TRIP indicator on).

Slowly turn the VOLTAGE ADJUST pot counter-clockwise until the unit resets (TRIP indicator off; NORMAL indicator on).

Set the TRIP DELAY adjustment to the desired amount of delay to prevent nuisance trips.

These adjustment settings will be correct for most applications. Should nuisance trips occur, even with the TRIP DELAY set, turn the VOLTAGE ADJUST pot slightly farther counter-clockwise. Any adjustments should be made in very small increments.

TYPICAL APPLICATION

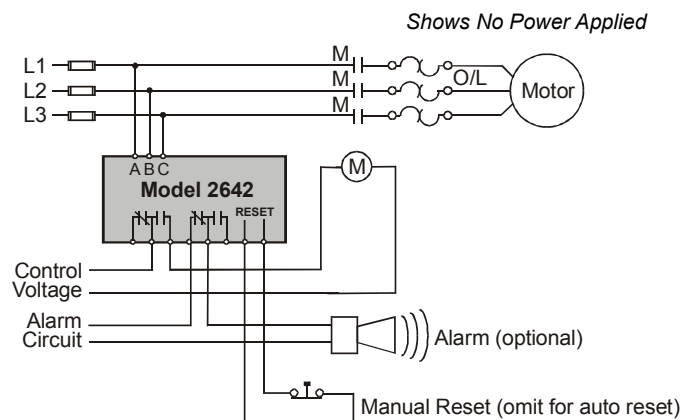

WARRANTY

The **Model 2642 3-Phase Monitor** is covered by Time Mark Corporation's exclusive **5-Year Unconditional Warranty**. Should this device fail, for any reason, within five years from the date of purchase, we will repair or replace it free. Contact the Time Mark Sales department, Monday through Friday; 8 a.m. to 5 p.m., CST, for further details.

Telephone: Main - (918) 438-1220
Sales - (800) 862-2875
Fax: (918) 437-7584

E-mail: sales@time-mark.com
Internet: http://www.time-mark.com



11440 East Pine Street
Tulsa, Oklahoma 74116
Doc No. 87A169 07/2011
© 2011 TIME MARK CORPORATION

TIME MARK is a division of  AEMT, Inc.

MODEL 2644

3-Phase Monitor



- Detects Phase Loss, Low Voltage and Phase Reversal
- Optional Restart Delay
- Automatic or Manual Reset
- 5 Year Unconditional Warranty



DESCRIPTION

The Model 2644 3-Phase Monitor continuously monitors 3-phase Wye or Delta systems for abnormal conditions.

The solid-state electronic sensing circuitry drives an internal DPDT relay, allowing the Model 2644 to operate two motor control circuits, or a control circuit and an alarm circuit. An adjustable trip delay reduces nuisance tripping caused by momentary voltage fluctuations on motor start-up.

An optional restart delay gives approximately a 3.5 minute delay when the relay drops out, to allow compressor head pressures to bleed off, in the event of short-term power failures.

Voltage adjustment ranges are sufficiently wide to allow for proper calibration to existing conditions. Both TRIP and NORM indicators are provided to aid in adjustment and system troubleshooting.

Automatic and manual reset versions are available. The Model 2644 Monitor is not sensitive to line current, and can be used with any size motor or compressor.

SPECIFICATIONS

AUTO Reset	A2644	B2644	C2644	D2644	EX2644
MANUAL Reset	A2644M	B2644M	C2644M	D2644M	EX2644M
RESTART DELAY	A2644R	B2644R	C2644R	D2644R	EX2644R
Nominal AC Voltage (phase to phase)	120VAC	208/240VAC	480VAC	575VAC	380VAC
Adjustment Range	85-120V	160-240V	380-480V	450-575V	300-400V
Frequency	60 Hz	60 Hz	60 Hz	60 Hz	50 Hz
Power Consumption	0.75W	1.5W	4.5W	7.5W	4.5W
Transient Protection	2500 VRMS for 10msec				
Repeat Accuracy	± 0.1% of setpoint (fixed conditions)				
Response Time	Adjustable 0.2 to 20 seconds ±10%				
Dead Band	Approximately 2%				
Output Contacts	DPDT 10 amps at 240VAC resistive				
Expected Relay Life	Mechanical: 10 million operations Electrical: 100,000 operations at rated load				
Operating Temp	- 20° to +131° F				
Humidity Tolerance	0 - 97% w/o condensation				
Enclosure Material	ABS plastic				
Mounting	Surface				
Weight	9.5 oz				
Agency Approvals	All versions UL Recognized and CSA Certified				

DIMENSIONS

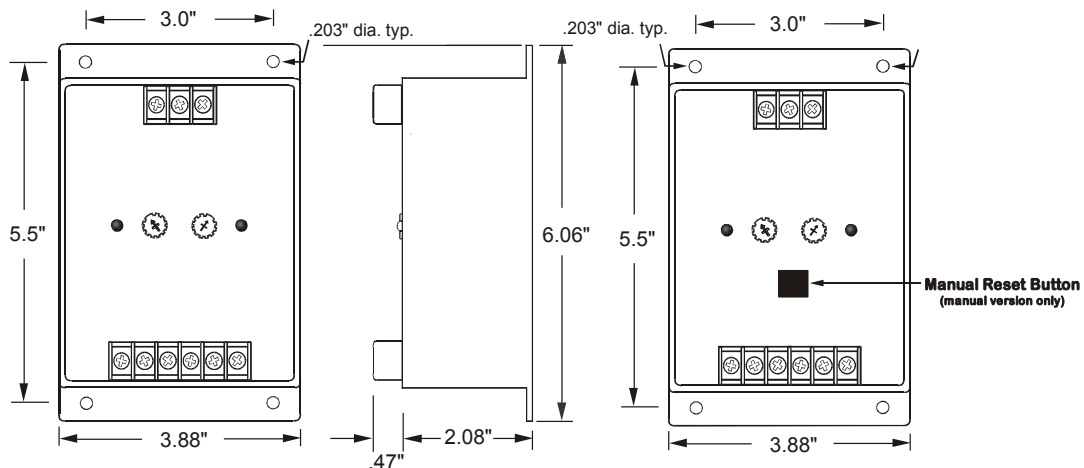

Telephone: Main - (918) 438-1220
Sales - (800) 862-2875
Fax: (918) 437-7584

E-mail: sales@time-mark.com
Internet: http://www.time-mark.com



TIME MARK
CORPORATION

11440 East Pine Street
Tulsa, Oklahoma 74116

Doc No. 87A146 07/2011
© 2011 TIME MARK CORPORATION

TIME MARK is a division of AEMT, Inc.

MODEL 2644 3-Phase Monitor

READ ALL INSTRUCTIONS BEFORE INSTALLING, OPERATING OR SERVICING THIS DEVICE.
KEEP THIS DATA SHEET FOR FUTURE REFERENCE.

GENERAL SAFETY

POTENTIALLY HAZARDOUS VOLTAGES ARE PRESENT AT THE TERMINALS OF THE MODEL 2644.
ALL ELECTRICAL POWER SHOULD BE REMOVED WHEN CONNECTING OR DISCONNECTING WIRING.
THIS DEVICE SHOULD BE INSTALLED AND SERVICED BY QUALIFIED PERSONNEL.

Installation Instructions

INSTALLATION

Turn both adjustment control potentiometers fully counter-clockwise.

Connect the 3-phase wires to the terminals marked **A**, **B** and **C**.

Connect the control wires to the terminals with the relay contact markings. The contact markings on the unit are the failed or tripped condition of the contacts. Apply power.

If the contacts do not transfer when power is applied (TRIPPED indicator on; NORMAL indicator off), press the RESET button and check that all three phases are present and of the correct voltage.

If all phases are correct, remove power from the unit, reverse any two of the **A**, **B** or **C** terminal wires (*phase rotation is reversed*), and re-apply power. The contacts should then transfer.

ADJUSTMENT PROCEDURE

Rotate the TRIP DELAY adjustment pot counter-clockwise.

Rotate the FAILURE LEVEL adjustment pot clockwise until the unit trips (NORMAL indicator off; TRIPPED indicator on).

Slowly rotate the FAILURE LEVEL adjustment pot counter-clockwise until the unit resets (TRIPPED indicator off; NORMAL indicator on). On 2644R versions there will be 3.5 minutes delay before NORMAL comes back on.

Set the TRIP DELAY adjustment to the desired amount of delay to prevent nuisance trips.

These adjustment settings will be correct for most applications. Should nuisance trips occur, even with the TRIP DELAY set, turn the FAILURE LEVEL adjustment pot slightly farther counter-clockwise. Any adjustments should be made in very small increments.

TYPICAL APPLICATION

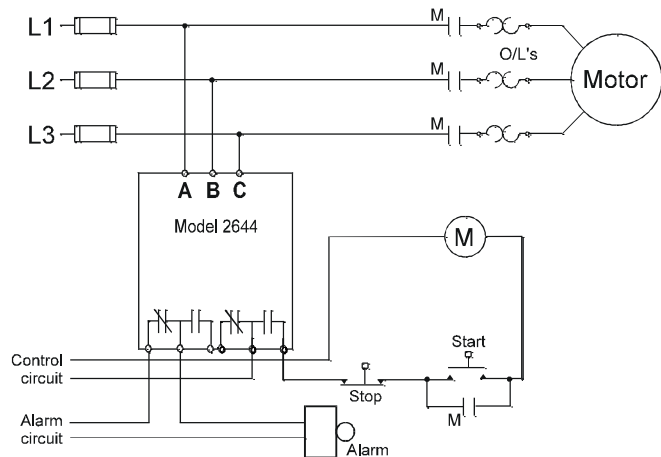

Shows No Power Applied

TROUBLESHOOTING

Should the Model 2644 3-Phase Monitor fail to operate properly, check that three phases are present and are of the correct voltage and phase rotation (*a Time Mark Model 108A or 108B Phase Sequence Detector should be used to verify phase rotation*). Check all fuses, and verify that all wiring connections are correct. Should problems persist, contact your local Time Mark Distributor, or the factory for further assistance.

WARRANTY

The **Model 2644 3-Phase Monitor** is covered by Time Mark Corporation's exclusive **5-Year Unconditional Warranty**. Should this device fail, for any reason, within five years from the date of purchase, we will repair or replace it free. Contact the Time Mark Sales department, Monday through Friday; 8 a.m. to 5 p.m., CST, for further details.

Telephone: Main - (918) 438-1220

Sales - (800) 862-2875

Fax: (918) 437-7584

E-mail: sales@time-mark.com

Internet: http://www.time-mark.com



TIME MARK
CORPORATION

11440 East Pine Street
Tulsa, Oklahoma 74116

Doc No. 87A146 07/2011
© 2011 TIME MARK CORPORATION

TIME MARK is a division of  **AEMT, Inc.**

MODEL 265

3-Phase Monitor

- HVAC or Compressor Applications
- Automatic Reset
- Adjustable Restart Delay
- Fast Trip Response
- UL Recognized; CSA Certified

DESCRIPTION

The **Model 265 3-Phase Monitor** continuously monitors 3-phase Wye or Delta systems for phase loss, low voltage and phase reversal. When properly adjusted, the Model 265 Monitor will detect phase loss on a loaded motor even when regenerated voltage is present.

The solid-state sensing circuit drives an internal relay, in a fail-safe configuration, i.e.; the relay is energized when correct voltage and phase rotation are applied.

Operating power for the Model 265 is drawn from the 3-phase lines being monitored. An adjustable timer delays restarting of the load, allowing up to five minutes for compressor head pressures to bleed off, in the event of short-term power failures.

The Model 265 Monitor is not sensitive to line current, and can be used with any size motor or compressor.

DIMENSIONS

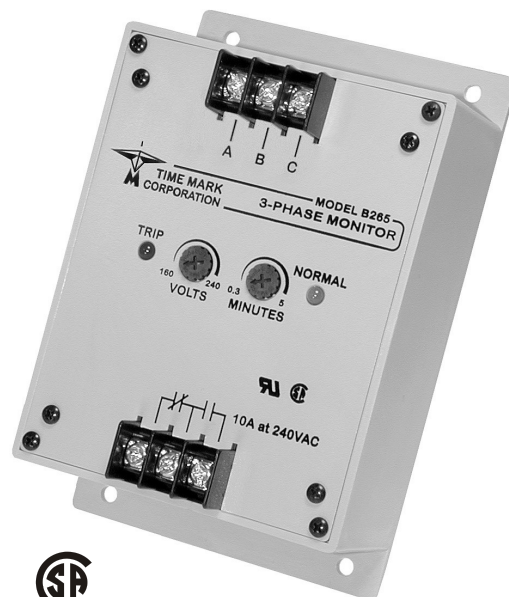
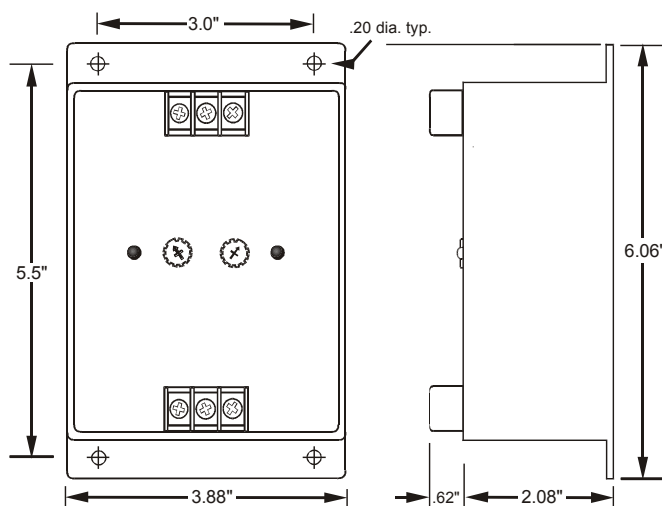

SPECIFICATIONS

AUTO Reset	A265	B265	C265	D265	EX265
Nominal AC Voltage (phase to phase)	120 VAC	208/240 VAC	480 VAC	575 VAC	380 VAC
Adjustment Range	85-120V	160-240V	380-480V	450-575V	300-380V
Frequency	60 Hz	60 Hz	60 Hz	60 Hz	50 Hz
Power Consumption	0.25W	0.5W	1.5W	2.5W	1.5W
Transient Protection	2500 VRMS for 10msec				
Repeat Accuracy	± 0.1% of set point (fixed conditions)				
Response Time	50 msec maximum				
Reset Time	Adjustable - 20 to 300 seconds ±10%				
Dead Band	Approximately 2%				
Output Contacts	SPDT 10 amps at 240 VAC resistive				
Expected Relay Life	Mech: 10 million operations Elec: 100,000 operations at rated load				
Operating Temperature	- 20° to +131° F				
Humidity Tolerance	0 - 97% w/o condensation				
Enclosure Material	ABS plastic				
Mounting	Surface				
Weight	10 oz.				
Agency Approvals	UL Recognized and CSA Certified				

Telephone: Main - (918) 438-1220
Sales - (800) 862-2875
Fax: (918) 437-7584

E-mail: sales@time-mark.com
Internet: http://www.time-mark.com



11440 East Pine Street
Tulsa, Oklahoma 74116

Doc No. 87A128 07/2011
© 2011 TIME MARK CORPORATION

TIME MARK is a division of  AEMT, Inc.

MODEL 265 3-Phase Monitor

READ ALL INSTRUCTIONS BEFORE INSTALLING, OPERATING OR SERVICING THIS DEVICE.
KEEP THIS DATA SHEET FOR FUTURE REFERENCE.

GENERAL SAFETY

POTENTIALLY HAZARDOUS VOLTAGES ARE PRESENT AT THE TERMINALS OF THE MODEL 265.
ALL ELECTRICAL POWER SHOULD BE REMOVED WHEN CONNECTING OR DISCONNECTING WIRING.
THIS DEVICE SHOULD BE INSTALLED AND SERVICED BY QUALIFIED PERSONNEL.

Installation Instructions

INSTALLATION

Rotate both the VOLTS and MINUTES adjustments counter-clockwise, to their lowest setting. The 3-phase wiring should be connected to the terminals marked **A**, **B** and **C**.

The control wiring will be connected to the opposite end of the unit, to the terminals with the relay contact markings. The markings printed on the Model 265 are the failed condition of the contacts.

When power is applied to the unit, the TRIP LED indicator should not be lit (the reset switch may have to be pressed on manual reset versions). If the TRIP indicator comes on when power is applied, check that all three phases are present and of the correct voltage. If the voltage is correct, remove power, then reverse two of the three phase wires.

Re-apply power. The TRIP indicator should not be on. After a brief delay (approx. 20 seconds) the LED indicator marked NORMAL should come on, and the contacts will transfer.

ADJUSTMENT SETTINGS

Rotate the VOLTS adjustment clockwise, until the contacts trip and the TRIP indicator illuminates.

Slowly rotate the VOLTS adjustment counter-clockwise, until the LED goes out (on manual reset versions, hold the RESET button down while making this adjustment).

After approximately 20 seconds, the contacts will transfer and the NORMAL indicator will come on. If nuisance trips occur, rotate the VOLTS adjustment slightly farther, counter-clockwise. This method of adjustment will be correct in most cases.

Set the MINUTES delay as required. Application dependent.

TROUBLESHOOTING

Should the Model 265 Monitor fail to operate properly, check that all three voltages are present, and are of the correct voltage level and phase rotation (a Model 108A or 108B Phase Sequence Detector should be used to verify phase rotation). Check all fuses and verify that all wiring connections are correct. If problems persist, contact your local Time Mark Distributor, or the factory for assistance.

TYPICAL APPLICATION

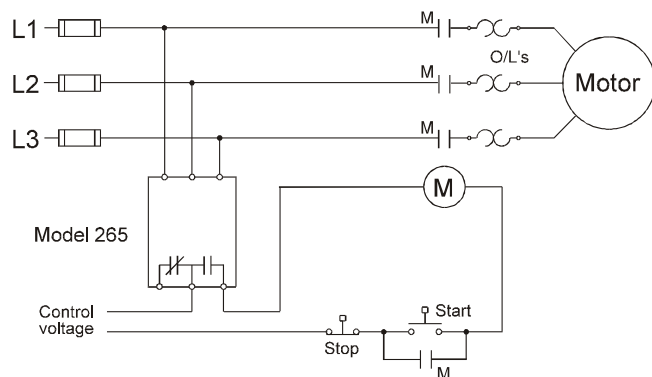

Shows No Power Applied

WARRANTY

The **Model 265 3-Phase Monitor** is covered by Time Mark Corporation's exclusive **5-Year Unconditional Warranty**. Should this device fail, for any reason, within five years from the date of purchase, we will repair or replace it free. Contact the Time Mark Sales department, Monday through Friday; 8 a.m. to 5 p.m., CST, for further details.

Telephone: Main - (918) 438-1220
Sales - (800) 862-2875
Fax: (918) 437-7584

E-mail: sales@time-mark.com
Internet: http://www.time-mark.com



11440 East Pine Street
Tulsa, Oklahoma 74116
Doc No. 87A128 07/2011
© 2011 TIME MARK CORPORATION

TIME MARK is a division of  AEMT, Inc.

MODEL 2652



3-Phase Monitor

- Detects Phase Loss, Low Voltage and Phase Reversal
- Adjustable Trip and Restart Delays
- Automatic or Manual Reset
- DPDT Output Contacts

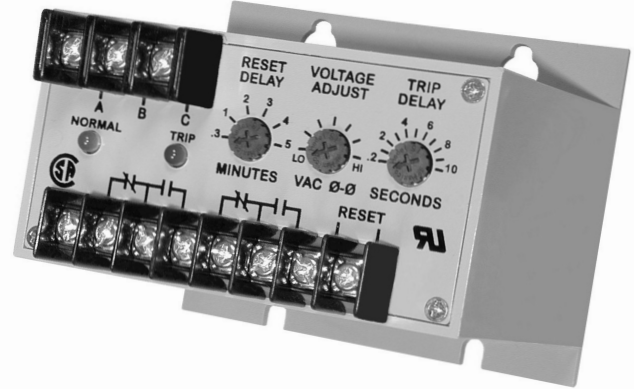

DESCRIPTION

The Model 2652 3-Phase Monitor is designed to protect motors, pumps, HVAC equipment, air compressors, etc., by sensing phase loss, low voltage or phase reversal.

With correct power applied, the DPDT output contacts transfer and drop out when a fault condition or loss of power occurs. An adjustable trip delay prevents nuisance tripping. The restart delay timer prevents short cycling, which is primarily used with HVAC and compressor motors.

The DPDT output contacts allow the Model 2652 to be used in control circuits and alarm circuits. The automatic reset can be converted to a manual reset by adding a normally closed switch.

Five different voltage versions of the Model 2652 can be adjusted over a wide operating range. This unit is housed in an ABS plastic surface-mount case to reduce space requirements.

SPECIFICATIONS

Model	A2652	B2652	C2652	D2652	EX2652
Nominal AC Voltage (phase to phase)	120VAC	208/240 VAC	480VAC	575VAC	380VAC
Adjustment Range	85-125V	160-260V	380-500V	450-600V	300-400V
Frequency	60 Hz				50 Hz
Power Consumption (per phase)	1.5W	2W	2.5W	3W	3.5W
Repeat Accuracy	± 0.5% of set point (fixed conditions)				
Response Time	Adjustable: 0.2 to 10 seconds ± 5%				
Reset Time	Adjustable: 0.3 to 5 minutes ± 5%				
Reset Type	Selectable: Automatic or Manual				
Dead Band	Approximately 2%				
Output Contacts	DPDT 10A at 240VAC resistive				
Expected Relay Life	Mech: 10 million operations Elec: 100,000 operations at rated load				
Operating Temp	- 20° to +131° F				
Humidity Tolerance	0 - 97% w/o condensation				
Enclosure Material	ABS plastic				
Mounting	Surface				
Weight	12 oz.				
Agency Approvals	UL Recognized and CSA Certified				

DIMENSIONS

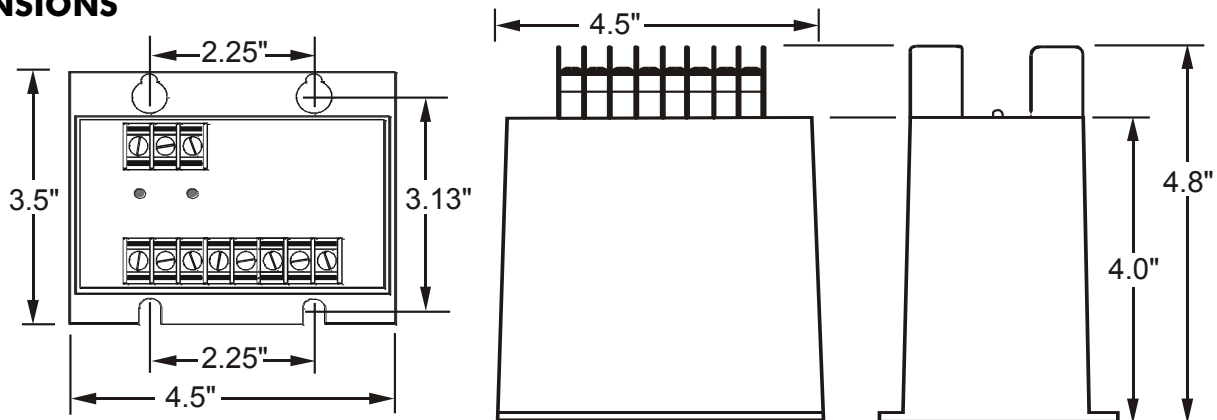

Telephone: Main - (918) 438-1220
Sales - (800) 862-2875
Fax: (918) 437-7584

E-mail: sales@time-mark.com
Internet: http://www.time-mark.com



TIME MARK
CORPORATION

11440 East Pine Street
Tulsa, Oklahoma 74116

Doc No. 87A170 07/2011
© 2011 TIME MARK CORPORATION

TIME MARK is a division of  AEMT, Inc.

MODEL 2652 3-Phase Monitor

READ ALL INSTRUCTIONS BEFORE INSTALLING, OPERATING OR SERVICING THIS DEVICE.
KEEP THIS DATA SHEET FOR FUTURE REFERENCE.

GENERAL SAFETY

POTENTIALLY HAZARDOUS VOLTAGES ARE PRESENT AT THE TERMINALS OF THE MODEL 2652.
ALL ELECTRICAL POWER SHOULD BE REMOVED WHEN CONNECTING OR DISCONNECTING WIRING.
THIS DEVICE SHOULD BE INSTALLED AND SERVICED BY QUALIFIED PERSONNEL.

Installation Instructions

INSTALLATION

Connect the 3-phase power to the terminals marked A, B, and C.

Connect the control circuit wiring to one set of the output terminals.

(Optional) Connect the second set of output terminals to an alarm circuit, or to the control circuit of a second load.

A standard wiring diagram is shown in the TYPICAL APPLICATION drawing. The contact markings are shown in the TRIPPED, or Power-OFF condition.

FOR MANUAL RESET, instead of the built-in automatic reset, install a normally-closed pushbutton switch across the terminals marked RESET. The manual reset leads should be kept as short as possible.

TYPICAL APPLICATION

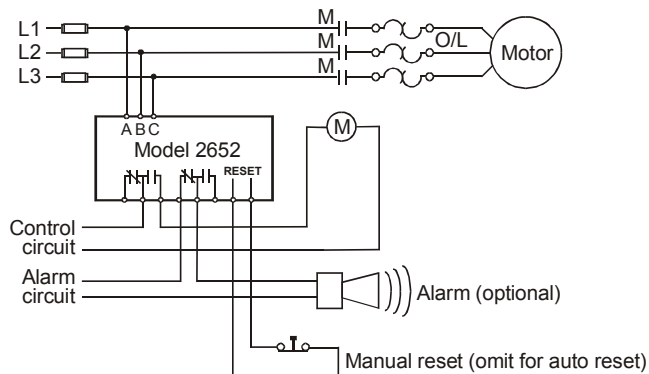

Shows No Power Applied

ADJUSTMENT

NOTE: When adjusting the Model 2652, you may want to jumper the control circuit contacts, and disconnect the alarm contacts connection, to prevent the unit from cycling the load, during set-up.

Turn the VOLTAGE ADJUST, RESET DELAY, and the TRIP DELAY pots fully counter-clockwise.

Turn the VOLTAGE ADJUST clockwise, until the unit trips (NORMAL indicator OFF; TRIP indicator ON).

Slowly turn the VOLTAGE ADJUST counter-clockwise until the unit resets (TRIP indicator OFF).

Set the TRIP DELAY and RESET DELAY to the desired time settings.

This trip level adjustment will be correct for most applications.

The TRIP DELAY should help prevent nuisance tripping due to power fluctuations, or motor start-ups. Should nuisance tripping still occur, increase the delay time a little, or turn the VOLTAGE ADJUST slightly farther counter-clockwise.

WARRANTY

The **Model 2652 3-Phase Monitor** is covered by Time Mark Corporation's exclusive **5-Year Unconditional Warranty**. Should this device fail, for any reason, within five years from the date of purchase, we will repair or replace it free. Contact the Time Mark Sales department, Monday through Friday; 8 a.m. to 5 p.m., CST, for further details.

Telephone: Main - (918) 438-1220
Sales - (800) 862-2875
Fax: (918) 437-7584

E-mail: sales@time-mark.com
Internet: http://www.time-mark.com



TIME MARK
CORPORATION

11440 East Pine Street
Tulsa, Oklahoma 74116

Doc No. 87A170 07/2011
© 2011 TIME MARK CORPORATION

TIME MARK is a division of  AEMT, Inc.

MODEL 269

Over & Under 3-Phase Monitor



- Monitors for High Voltage, Low Voltage, Phase Loss & Phase Reversal
- 4 Voltage Ranges
- Automatic Reset
- 5 Year Unconditional Warranty



DESCRIPTION

The Model 269 Over & Under 3-Phase Monitor continuously monitors 3-phase lines for high voltage, low voltage, phase loss or phase reversal. This device features a solid-state voltage and phase angle sensing circuit, which drives a SPDT output relay.

The Model 269 is independent of the system load, and may be used on any horsepower motor. When phase sequence is correct, and the voltage remains between the upper and lower trip points, the output relay remains energized. When a fault condition is sensed, the output relay drops out.

The Model 269 does not require a neutral connection, and can be used on Wye or Delta systems. Each of the four voltage versions can be adjusted over a wide range. An adjustable trip delay (1-10 seconds) prevents nuisance tripping. OVER and UNDER voltage failure indicators aid in calibration and system troubleshooting.

SPECIFICATIONS

Model	A269	B269	C269	EX269
Nominal AC Voltage (phase to phase)	120VAC	208/240VAC	480VAC	380VAC
Adj Range - Upper	110 - 145V	210 - 280V	400 - 540V	350 - 450V
- Lower	80 - 115V	170 - 240V	380 - 460V	300 - 400V
Frequency	60 Hz			50 Hz
Power Consumption	1.5W	3W	6W	6W
Transient Protection	2500VRMS for 10 msec			
Repeat Accuracy	± 0.1% of set point (fixed conditions)			
Response Time	Adjustable from 1-10 seconds ±5%			
Reset Time	0.25 seconds			
Reset Type	Automatic			
Dead Band	Approximately 2%			
Output Contacts	SPDT 10A at 240VAC resistive			
Expected Relay Life	Mech:	10 million operations		
	Elec:	100,000 operations at rated load		
Operating Temp	- 20° to +130° F			
Humidity Tolerance	0-97% w/o condensation			
Enclosure Material	ABS Plastic			
Mounting	Surface			
Weight	9 oz.			
Agency Approval	UL Listed & CSA Certified			

DIMENSIONS

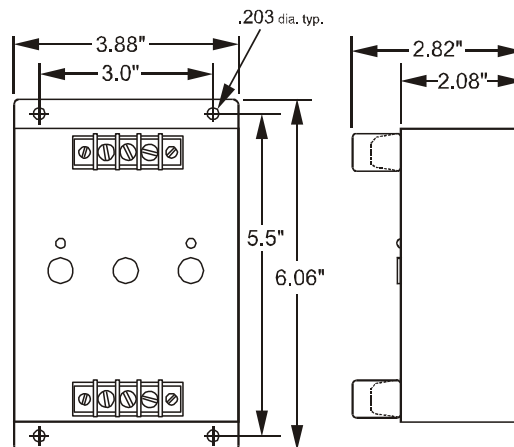

Telephone: Main - (918) 438-1220
Sales - (800) 862-2875
Fax: (918) 437-7584

E-mail: sales@time-mark.com
Internet: http://www.time-mark.com



TIME MARK
CORPORATION

11440 East Pine Street
Tulsa, Oklahoma 74116

Doc No. 87A141 07/2011
© 2011 TIME MARK CORPORATION

TIME MARK is a division of  AEMT, Inc.

MODEL 269 Over & Under 3-Phase Monitor

READ ALL INSTRUCTIONS BEFORE INSTALLING, OPERATING OR SERVICING THIS DEVICE.
KEEP THIS DATA SHEET FOR FUTURE REFERENCE.

GENERAL SAFETY

POTENTIALLY HAZARDOUS VOLTAGES ARE PRESENT AT THE TERMINALS OF THE MODEL 269 .
ALL ELECTRICAL POWER SHOULD BE REMOVED WHEN CONNECTING OR DISCONNECTING WIRING.
THIS DEVICE SHOULD BE INSTALLED AND SERVICED BY QUALIFIED PERSONNEL.

Installation Instructions

WARNING

THE MODEL 269 IS NOT TO BE USED IN APPLICATIONS WHERE VOLTAGES TO BE MONITORED OR SWITCHED WILL EXCEED VOLTAGE SPECIFICATIONS FOR THE PARTICULAR UNIT. SEE 'ADJUST-MENT RANGE' IN THE TABLE ON THE REVERSE SIDE OF THIS DATA SHEET.

INSTALLATION

Connect 3-phase wiring to the terminals marked **A**, **B** and **C**.

Connect the control wires to the terminals with the relay contact markings. The markings shown are in a *TRIPPED* condition.

Apply power. If the indicator lights are ON, and the contacts do not transfer when power is applied, check that all three phases are present and of the correct voltage. If all phases are correct, rotate the UNDER VOLTS adjustment fully counter-clockwise, and the OVER VOLTS adjustment fully clockwise.

If the contacts still do not transfer, remove power from the unit, and reverse two of the three input wires. Re-apply power. The contacts should then transfer (*LED-off*).

ADJUSTMENT

Turn the DELAY SECONDS trip delay adjustment counter-clockwise.

Rotate the UNDER VOLTS adjustment slowly clockwise until the contacts transfer to a tripped condition (*LED-on*).

Slowly turn the UNDER VOLTS adjustment back counter-clockwise until the contacts reset to the normal condition (*LED-off*).

Rotate the OVER VOLTS adjustment counter-clockwise until the contacts trip (*LED-on*).

Slowly turn the OVER VOLTS adjustment back clockwise until the contacts reset to the normal condition (*LED-off*).

These settings will be correct for most installations.

Set the SECONDS delay adjustment to the desired amount of trip delay. This delay will help prevent nuisance tripping.

Should nuisance tripping still occur, turn the OVER VOLTS, and UNDER VOLTS adjustments slightly farther.

NOTE: In eliminating nuisance tripping, the voltage adjustments should be rotated in very small increments, until the true nuisance trips no longer occur.

TYPICAL APPLICATION

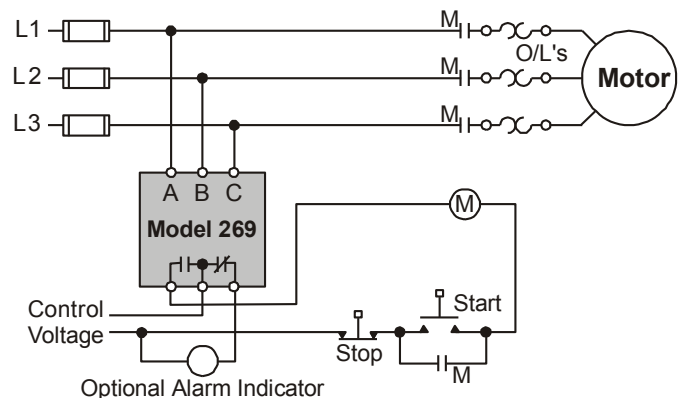

Shows No Power Applied

TROUBLESHOOTING

Should the Model 269 fail to operate properly, check that all three voltages are present, and are of the correct level. Check all fuses, and verify that all wiring connections are correct. Should problems persist, contact your local Time Mark Distributor, or the factory for further assistance.

WARRANTY

The **Model 269 Over & Under 3-Phase Monitor** is covered by Time Mark Corporation's exclusive **5-Year Unconditional Warranty**. Should this device fail, for any reason, within five years from the date of purchase, we will repair or replace it free. Contact the Time Mark Sales department, Monday through Friday; 8 a.m. to 5 p.m., CST, for further details.

Telephone: Main - (918) 438-1220

Sales - (800) 862-2875

Fax: (918) 437-7584

E-mail: sales@time-mark.com

Internet: http://www.time-mark.com



TIME MARK
CORPORATION

11440 East Pine Street
Tulsa, Oklahoma 74116

Doc No. 87A141 07/2011
© 2011 TIME MARK CORPORATION

TIME MARK is a division of  AEMT, Inc.

MODEL 269R

Over & Under 3-Phase Monitor

- Monitors for High Voltage, Low Voltage, Phase Loss & Phase Reversal
- 4 Voltage Ranges
- Automatic Reset
- 5 Year Unconditional Warranty
- Adjustable Restart Delay



DESCRIPTION

The Model 269R Over & Under 3-Phase Monitor continuously monitors 3-phase lines for high voltage, low voltage, phase loss or phase reversal. This device features a solid-state voltage and phase angle sensing circuit, which drives a SPDT output relay.

The Model 269R is independent of the system load, and may be used on any horsepower motor. When phase sequence is correct, and the voltage remains between the upper and lower trip points, the output relay remains energized. When a fault condition is sensed, the output relay drops out.

The Model 269R does not require a neutral connection, and can be used on Wye or Delta systems. Each of the four voltage versions can be adjusted over a wide range. An adjustable restart delay (0.3-5 minutes) allows compressor head pressures to bleed off, in the event of short-term power failures. OVER and UNDER voltage failure indicators aid in calibration and system troubleshooting.

DIMENSIONS

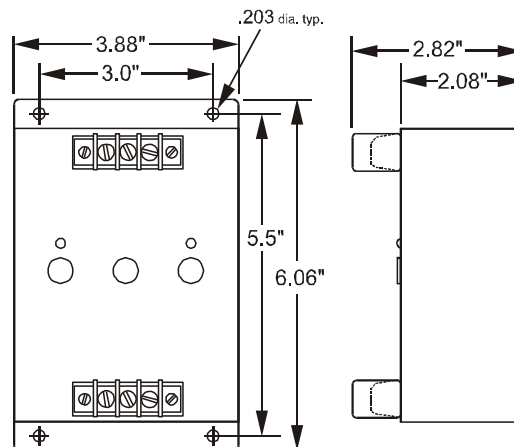

SPECIFICATIONS

Model	A269R	B269R	C269R	EX269R
Nominal AC Voltage (phase to phase)	120VAC	208/240VAC	480VAC	380VAC
Adj Range - Upper - Lower	110 - 145V 80 - 115V	210 - 280V 170 - 240V	400 - 540V 380 - 460V	350 - 450V 300 - 400V
Frequency	60 Hz			50 Hz
Power Consumption	1.5W	3W	6W	6W
Transient Protection	2500VRMS for 10 msec			
Repeat Accuracy	± 0.1% of set point (fixed conditions)			
Response Time	4 ±2 seconds fixed			
Reset Time	Adjustable 0.3 to 5 minutes			
Reset Type	Automatic			
Dead Band	Approximately 2%			
Output Contacts	SPDT 10A at 240VAC resistive			
Expected Relay Life	Mech: 10 million operations Elec: 100,000 operations at rated load			
Operating Temp	- 20° to +130° F			
Humidity Tolerance	0-97% w/o condensation			
Enclosure Material	ABS Plastic			
Mounting	Surface			
Weight	9 oz.			

Telephone: Main - (918) 438-1220
Sales - (800) 862-2875
Fax: (918) 437-7584

E-mail: sales@time-mark.com
Internet: http://www.time-mark.com



TIME MARK
CORPORATION

11440 East Pine Street
Tulsa, Oklahoma 74116

Draft Copy 07/2011
© 2011 TIME MARK CORPORATION

TIME MARK is a division of  AEMT, Inc.

MODEL 269R Over & Under 3-Phase Monitor

READ ALL INSTRUCTIONS BEFORE INSTALLING, OPERATING OR SERVICING THIS DEVICE.
KEEP THIS DATA SHEET FOR FUTURE REFERENCE.

GENERAL SAFETY

POTENTIALLY HAZARDOUS VOLTAGES ARE PRESENT AT THE TERMINALS OF THE MODEL 269R .
ALL ELECTRICAL POWER SHOULD BE REMOVED WHEN CONNECTING OR DISCONNECTING WIRING.
THIS DEVICE SHOULD BE INSTALLED AND SERVICED BY QUALIFIED PERSONNEL.

Installation Instructions

INSTALLATION

Rotate both the UNDER VOLTS and MINUTES adjustments counter-clockwise, and OVER VOLTS adjustment clockwise. The 3-phase wiring should be connected to the terminals marked **A, B** and **C**.

The control wiring will be connected to the opposite end of the unit, to the terminals with the relay contact markings. The markings printed on the Model 269R are the failed condition of the contacts.

When power is applied to the unit, the TRIP LED indicator should not be lit (the reset switch may have to be pressed on manual reset versions). If the TRIP indicator comes on when power is applied, check that all three phases are present and of the correct voltage. If the voltage is correct, remove power, then reverse two of the three phase wires.

Re-apply power. The TRIP indicator should not be on. After a brief delay (approx. 20 seconds) the contacts will transfer.

ADJUSTMENT SETTINGS

Rotate the UNDER VOLTS adjustment clockwise, until the contacts trip and the UNDER indicator illuminates.

Slowly rotate the UNDER VOLTS adjustment counter-clockwise, until the LED goes out (on manual reset versions, hold the RESET button down while making this adjustment). Rotate the OVER VOLTS adjustment counter-clockwise, until the contacts trip and the OVER trip indicator illuminates. Slowly rotate the OVER VOLTS adjustment clockwise until the LED goes out.

After approximately 20 seconds, the contacts will transfer and the NORMAL indicator will come on. If nuisance trips occur, rotate the VOLTS adjustment slightly farther, counter-clockwise. This method of adjustment will be correct in most cases.

Set the MINUTES delay as required. Application dependent.

TROUBLESHOOTING

Should the Model 269R Monitor fail to operate properly, check that all three voltages are present, and are of the correct voltage level and phase rotation (a Model 108A or 108B Phase Sequence Detector should be used to verify phase rotation). Check all fuses and verify that all wiring connections are correct. If problems persist, contact your local Time Mark Distributor, or the factory for assistance.

TYPICAL APPLICATION

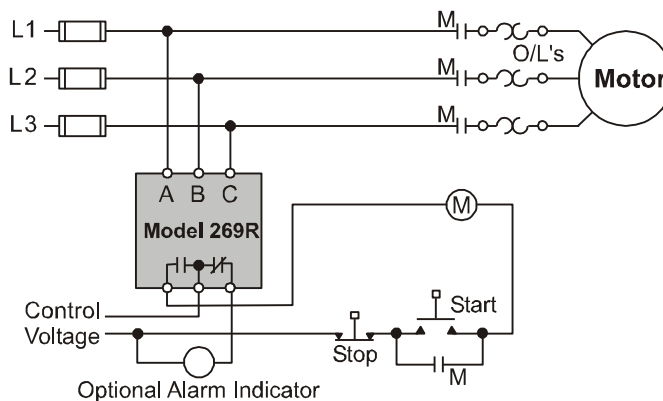

Shows No Power Applied

WARRANTY

The **Model 269R 3-Phase Monitor** is covered by Time Mark Corporation's exclusive **5-Year Unconditional Warranty**. Should this device fail, for any reason, within five years from the date of purchase, we will repair or replace it free. Contact the Time Mark Sales department, Monday through Friday; 8 a.m. to 5 p.m., CST, for further details.

Telephone: Main - (918) 438-1220

Sales - (800) 862-2875

Fax: (918) 437-7584

E-mail: sales@time-mark.com

Internet: http://www.time-mark.com



TIME MARK
CORPORATION

11440 East Pine Street
Tulsa, Oklahoma 74116

Draft Copy 07/2011

© 2011 TIME MARK CORPORATION

TIME MARK is a division of  AEMT, Inc.